



ELECTRICAL COMMUNICATION

*Technical Journal of the
International Telephone and Telegraph Corporation
and Associate Companies*

RADAR

DEVELOPMENT OF AIRCRAFT INSTRUMENT LANDING SYSTEMS

SPECIAL ASPECTS OF HIGH FREQUENCY FLEXIBLE BALANCED CABLES

**SPECIAL TRANSMISSION PROBLEMS IN SOLID DIELECTRIC
HIGH FREQUENCY CABLE**

UNITED AIR LINES' REPERFORATOR SWITCHING SYSTEM

ELECTRON TRAJECTORIES IN A PLANE DIODE—A GENERAL RESULT

SCHOTTKY'S THEORIES OF DRY SOLID RECTIFIERS

DEVELOPMENTS IN CARRIER TELEGRAPH TRANSMISSION IN AUSTRALIA

RECENT TELECOMMUNICATION DEVELOPMENTS

1945

VOL. 22

No. 3

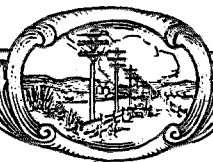

ELECTRICAL COMMUNICATION

Technical Journal of the
INTERNATIONAL TELEPHONE AND TELEGRAPH CORPORATION
and Associate Companies

H. T. KOHLHAAS, Editor

EDITORIAL BOARD

C. B. Allsopp H. Busignies H. H. Buttner G. Deakin E. M. Deloraine T. M. Douglas
Sir Frank Gill W. Hatton E. Labin E. S. McLarn H. M. Pease
E. D. Phinney Haraden Pratt E. N. Wendell

Published Quarterly by the

INTERNATIONAL TELEPHONE AND TELEGRAPH CORPORATION

67 BROAD STREET, NEW YORK 4, N.Y., U.S.A.

Sosthenes Behn, President

Charles D. Hilles, Jr., Vice President and Secretary

Subscription, \$1.50 per year; single copies, 50 cents

Volume 22

1945

Number 3

CONTENTS

	PAGE
RADAR	171
DEVELOPMENT OF AIRCRAFT INSTRUMENT LANDING SYSTEMS ...	179
<i>By H. H. Buttner and A. G. Kandoian</i>	
SPECIAL ASPECTS OF HIGH FREQUENCY FLEXIBLE BALANCED CABLES	193
<i>By N. Marchand</i>	
SPECIAL TRANSMISSION PROBLEMS IN SOLID DIELECTRIC HIGH FREQUENCY CABLE	198
<i>By A. G. Kandoian</i>	
UNITED AIR LINES' REPERFORATOR SWITCHING SYSTEM	203
<i>By R. E. Hanford</i>	
ELECTRON TRAJECTORIES IN A PLANE DIODE—A GENERAL RESULT	212
<i>By Léon Brillouin</i>	
SCHOTTKY'S THEORIES OF DRY SOLID RECTIFIERS	217
<i>By J. Joffe</i>	
DEVELOPMENTS IN CARRIER TELEGRAPH TRANSMISSION IN AUS- TRALIA	226
<i>By R. E. Page and J. L. Skerrett</i>	
RECENT TELECOMMUNICATION DEVELOPMENTS	246

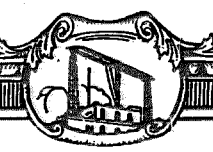



**SOME I. T. & T. SYSTEM
PLANTS AND LABORA-
TORIES FREED FROM
AXIS DOMINATION**

**LES LABORATOIRES, LE MATÉRIEL
TÉLÉPHONIQUE, PARIS**

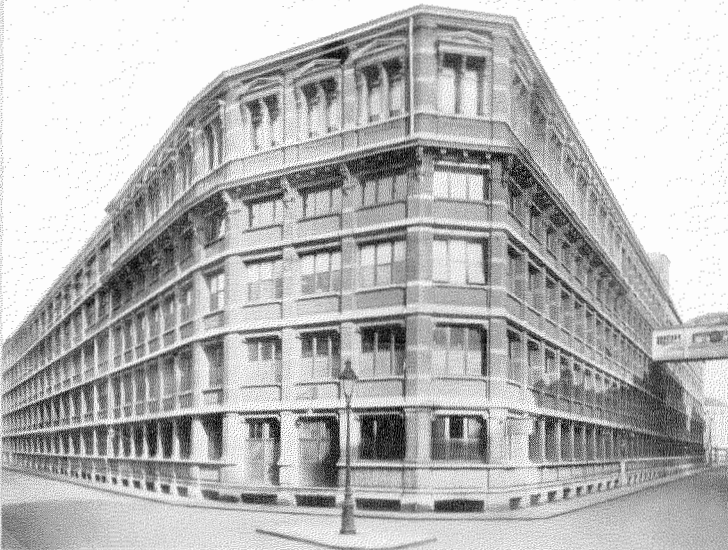

**BELL TELEPHONE MANUFACTURING
COMPANY, ANTWERP**



LE MATÉRIEL TÉLÉPHONIQUE, PARIS



**COMPAGNIE GÉNÉRALE DE
CONSTRUCTIONS TÉLÉPHONIQUES,
PARIS**

Radar

Editor's Note: The basic principles of radiolocation or radar were described in "Wireless World," February, 1945, by R. L. Smith-Rose of the (British) National Physical Laboratory. His article is reprinted below.

Mr. Smith-Rose in his description associates the development of radiolocation (or radar) with that of the "radio searchlight" first developed and demonstrated in 1931 across the Strait of Dover by the I. T. & T. System Laboratories. Known as the Anglo-French Micro-ray Link, it is interesting to note that reflectors, sharply concentrated beams and frequency used in this link and in much modern radar equipment are strikingly similar. Moreover, through the years following 1931, the I. T. & T. Laboratories intensively studied micro-ray phenomena—knowledge that proved highly useful to them and to others in accelerating the development of radar. High-spots of the results achieved, as recorded in the pages of *Electrical Communication*, are therefore also reviewed as pertinent and interesting.*

Radiolocation †

When England entered the European War in September, 1939, she was already partially equipped with a new technical weapon in the form of a novel application of radio waves to the detection of objects such as aircraft and ships. The technique of this new weapon was then known as RDF, those mysterious initials, the precise meaning of which was never quite clear even to the original band of workers in this field. At a later stage the term Radiolocation was introduced, and this certainly had the advantage of being almost self-explanatory; but it has now to be admitted with some regret that, in the technical field at any rate, this has been largely eclipsed by the arrival from America of the short word Radar, which we are told means "radio-detecting-and-ranging."

Radiolocation or Radar may be described as the art of using radio waves for the detection and location of an object, fixed or moving, by the aid of the difference of its electrical properties from those of the medium adjacent to or surrounding it. An intrinsic feature of the art is that no co-operation whatsoever is required of the object being detected, and it is in this particular sense that RDF, as it was formerly known, differs from the long-established practice of radio direction-finding. The technique of direction-finding, as known and experimented with for half a century, is really confined to the determination of the direction of a primary

source of radio waves, either for intelligence purposes or for use as a navigational aid. In such cases the source of the radio waves may be on the one hand an illicit sending station, the position of which it is required to determine; or on the other hand, the source may be a friendly radio beacon transmitter, for the use of ships or aircraft fitted with direction finders to assist the navigator in determining his own position. A third source of radio waves which are not of man-made origin, is a lightning flash; and for many years past, the positions of such lightning flashes have been determined by using two or more radio direction finders to determine the direction of arrival of the electric waves radiated from each flash. Such measurements have contributed materially to our knowledge of the nature and origin of atmospheric phenomena as they are encountered in radio communication, and they have also been applied to the location of storm centres in meteorology.

The new art of radiolocation, however, as developed during the past two decades, requires no such co-operation, as it were, on the part of the object under examination; the latter, be it an aeroplane, ship, building or human being, is merely required to reflect or scatter some of the radiation which reaches it from a radio transmitter forming part of the whole Radar installation. The detected object is thus merely a source of secondary radiation which results from its being illuminated, as it were, by the incident radiation from the primary sending station. With this definition of the subject with which we are concerned, we may now proceed to an explanation of the fundamental principles forming the basis of this new application of radio waves.

* In England, Standard Telephones and Cables, Ltd.; in France, Les Laboratoires, Le Matériel Téléphonique.

† "Radiolocation, 1. Basic Principles," by R. L. Smith-Rose, D.Sc., Ph.D., M.I.E.E., F.I.R.E. (National Physical Laboratory), *Wireless World*, February, 1945.

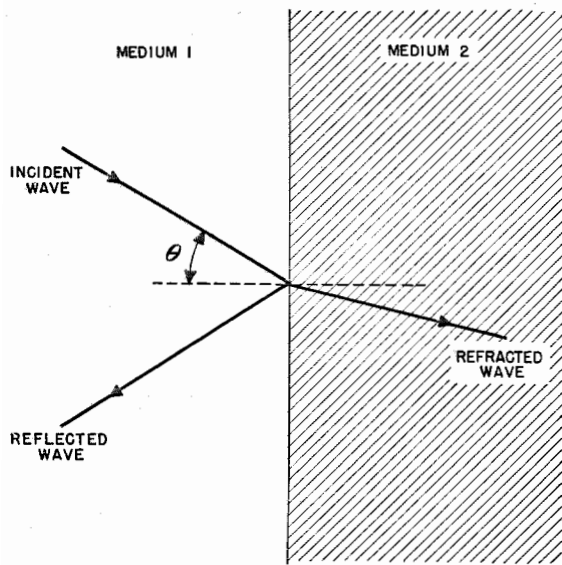

Fig. 1—Illustrating the production of reflected and refracted waves when the incident waves strike the boundary surface of two media (1 and 2) having different electrical properties.

Reflection and Refraction of Electric Waves

In his classical experiments carried out towards the end of last century, Hertz demonstrated experimentally the salient properties of the newly-produced electromagnetic waves, and showed that these were similar to those of light waves when allowance is made for the difference in wavelength, the former waves being a few million times as long as those of yellow light. Hertz showed that these long electric waves could be reflected from metallic sheets, concentrated into beams by suitably shaped reflectors, and refracted by passage through prisms of insulating material. These phenomena are due to the fact that when electric waves, of whatever length, impinge on the boundary separating two media of different electrical properties, the path of transmission of the waves is altered; some of the wave energy passes across the boundary, but in doing so its path is bent or refracted; another portion of the wave energy is turned back from the boundary, and forms the reflected portion of the waves on the same side as the incident waves (see Fig. 1). The relative magnitudes of the reflected and refracted waves depend upon the electrical properties of the media on the two sides of the boundary, the angle of incidence (θ in

Fig. 1), and the frequency or wavelength of the waves. If these quantities are known, the reflecting power of the surface of separation of the two media can be calculated; and in many practical cases, this calculation is made easier by the fact that the first medium is air under normal atmospheric conditions, when its electrical conductivity is very small and its dielectric constant is approximately unity. If the second medium is a sheet of copper, of which the conductivity is very high, nearly all the incident energy in the arriving waves will be reflected; this is the result of the re-radiation from the conduction currents set up in the copper sheet by the arriving waves. Alternatively, the same result will be obtained with radio waves if the second medium consists of fresh water; for although in this case the conductivity is low, its permittivity is high and thus strong dielectric currents will be set up, particularly at high radio frequencies. In the case of soil or earth, which has both a moderate conductivity and an intermediate value of permittivity, a portion only of the incident wave energy will be reflected, the remaining energy passing into the medium to form the refracted waves.

From these considerations it is seen that reflection of radio waves is caused at a discontinuity or boundary between two media, and when waves in air strike a surface, which may be either a metallic conductor or an insulating medium, the waves are reflected in some degree by the surface. If this surface is smooth in the sense that it is free from irregularities of a size approaching the wavelength, then the reflection is of the specular type such as we meet with in light waves; and in such cases if the waves impinge normally on the surface, they will be reflected back along the original direction towards the source of the incident waves. If the surface is not sufficiently smooth the reflection will take place in various directions, or the incident waves are scattered, as it is termed; and in this case only a portion of the reflected or scattered energy is returned along the path of the incident waves.

Measurements with Light Waves

It is thus easy to understand how light reflected from solid or liquid media enables us to

see the existence of these objects, and Fig. 2 illustrates the manner in which a searchlight enables a target—aircraft or cloud—to be seen by an observer situated at R, who can then determine its bearing and angle of elevation. This is an art which is well known and has been practised for a long time; but it suffers from one serious drawback: this simple combination of a searchlight and an observer does not enable the distance of the target to be determined.

In order to make this valuable addition to the observation, it is necessary to interrupt or modulate the beam of light in such a way that the time of transit of the waves between the source and target and then back to the receiver may be determined. This important addition to the technique of visual observation was actually made as long ago as 1849 by Fizeau in his classical experiments to measure the speed with which light waves travel. Fizeau used a mechanical method of measuring the time of transit of an interrupted beam of light over a return path about three or four miles long. At that time, the distance was accurately measured and so the velocity of the waves determined: but if, as is done nowadays, a knowledge of the wave velocity is assumed, then the length of an unknown path with a reflector at the end of it can be determined.

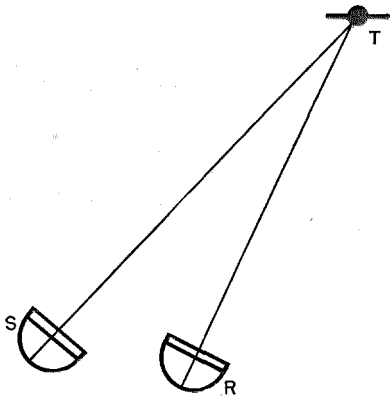

Fig. 2—The searchlight S illuminates the target T, and some of the scattered light can be detected by the observer at R. The direction, both azimuth and elevation, of the target is thus determined, but not its distance or range.

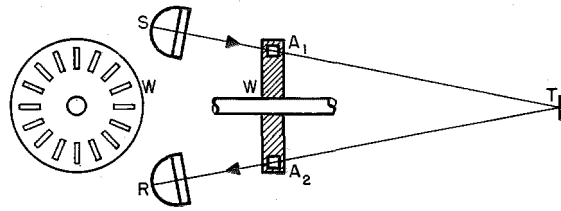

Fig. 3—Adaptation of Fizeau's classical experiment to determine the speed of light. If the speed is known, the distance A_1TA_2 can be measured by the same technique.

A possible arrangement of this method of determining the distance of a reflecting object by the aid of light waves is illustrated in principle in Fig. 3. As before, light from a source S is transmitted to a target at T whence some of it is reflected back to a detector or receiver at R. In front of both S and R rotates a disc or wheel W, with an even number of radial apertures in it, so that the beam of light is alternately interrupted and allowed to pass. With the disc stationary the outgoing and incoming beams pass through the corresponding slots at the end of a diameter. As the disc is rotated and its speed gradually increased, some of the light which has passed through a slot A_1 in front of S will be cut off, because by the time it has traversed A_1TA_2 the corresponding slot A_2 will have moved round through a small angle. As the rate of rotation of the disc is increased, a speed will be reached at which the returning light will be cut off by the portion of the disc between the slots. As the speed of the disc is further raised the light will again be perceived at R, since while the light is traversing the path A_1TA_2 , the disc will have rotated through an angle equal to that separating adjacent slots. Hence from an observation of the speed of the disc under these conditions, and assuming the velocity of the waves, the distance A_1T can be determined. From this type of measurement and the associated observations of the angular directions of the reflector T in both the horizontal and vertical planes, the position of T in three-dimensional space becomes known.

This, in essence, is the fundamental principle of radiolocation as it is practised to-day. The writer is not aware to what extent, if at all, it became practicable to use it with light waves, but in any case, its use in this way would be

severely limited to ranges normally detectable by the human eye* under conditions of darkness and the occurrence of clear weather. Furthermore, in typical circumstances, the time intervals to be measured are very small—about 10 microseconds per mile—and the consequent practical problems involved in the rotation of the disc at the required speed are not easily solved. The use of this technique, initiated by physicists in the latter half of the nineteenth century, thus remained limited to determinations of the velocity of light; and the resulting measurements attained a surprisingly high accuracy, notably due to the activities of Professor A. A. Michelson, who worked in this field over a period of some fifty years. In more recent times, the principle of the method was varied by modulating the beam of light at a radio frequency instead of interrupting it by a mechanical method.

The Principles of Modern Radar

The reader is now in a position to appreciate and understand the elementary principles of

* Modern photoelectric cell technique could be used with advantage at the present time.

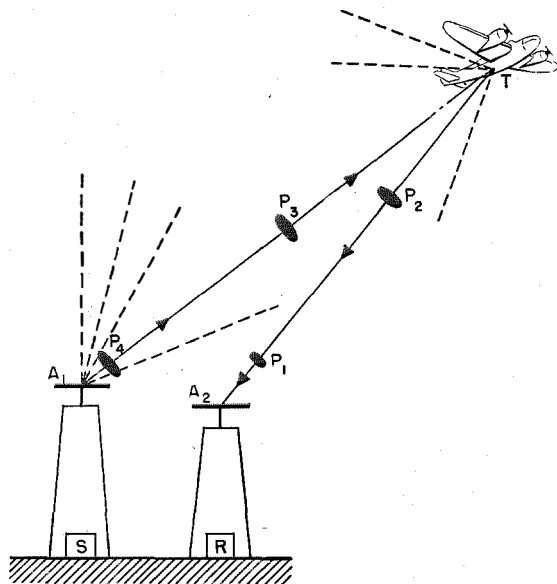

Fig. 4—The use of pulses of radio waves P_1 – P_4 , emitted at regular intervals to determine the distance of the target T from the sending and receiving aerials, A_1 , A_2 , by measuring the time of travel of the pulses along the path A_1TA_2 .

radiolocation, or Radar, in so far as these are analogous to the experiments with light waves described above, but making use of the longer electric waves in the radio-frequency portion of the spectrum. A complete station consists of a combination of a transmitter and receiver. The transmitting or sending portion emits radiation over a broad arc in the approximate direction it is desired to explore. When this radiation strikes an object having an appreciable conductivity or dielectric constant, some of the energy is reflected or scattered back towards the receiver which is installed moderately close to the transmitter. If the latter emits the radio waves in short trains or pulses, the time of transit of these to the reflecting target and back to the receiver can be measured, by displaying the received signals on the screen of a cathode-ray tube. The arrangement is indicated schematically in Fig. 4, where successive pulses $P_1P_2P_3P_4$ have been emitted from the sending aerial A_1 , the first two pulses having already reached the target and been reflected back towards the receiving aerial A_2 . It is now required to determine the time of transit of any one of the pulses over the path A_1TA_2 .

The pulses of radio-frequency oscillations arriving at the receiving aerial are suitably amplified and rectified, and then applied to the vertical deflecting plates of a cathode-ray tube. If the horizontal deflecting plates are connected to a suitable time-base circuit operating in synchronism with the pulse generating circuit in the transmitter, then for a fixed distance A_1TA_2 , the received pulses will appear superimposed on one another as vertical deflections from the horizontal time-base. If, furthermore, the time-base is made to start its deflection from the left-hand side of the screen at the same instant as the pulse of radiation leaves the sending aerial, then the distance along the time-base from its origin to the position of the pulse displayed on it is a measure of the length of path A_1TA_2 . The type of picture obtained on the screen of the cathode-ray tube is illustrated in Fig. 5, in which the line OA represents the time-base which is locked to the transmitter in such a way that the length OT_1 represents the time taken by an emitted pulse to arrive back at the receiver after

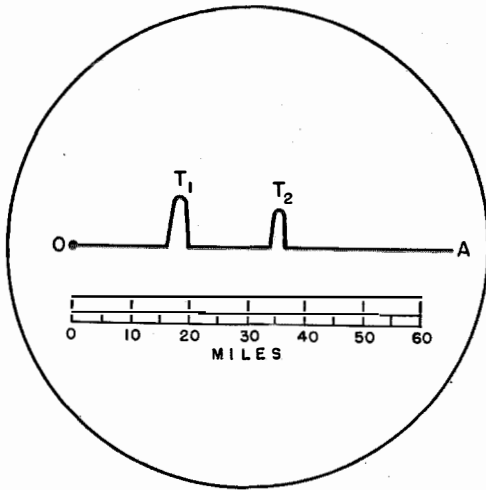

Fig. 5—Type of echo display seen on screen of cathode-ray tube. The fluorescent spot sweeps along the time base OA in synchronism with the transmitted pulses. The received echoes from two targets are seen at a distance from O corresponding to the time taken for the pulses to travel to and from the targets T_1 and T_2 . The time-base can be provided with a range scale as shown.

reflection from a target T_1 . As we know that the velocity of radio waves is substantially 186,000 miles per second, the scale of the time-base can be graduated in miles, so that the distance of the target T_1 is seen to be about 19 miles. A second received pulse is seen at T_2 returned from another target at a range of about 35 miles. If one or both of these targets are moving, their changes in position are indicated by the movement of the pulses along the base-line on the screen of the cathode-ray tube towards or away from the point O.

The amplitude of the pulse on the tube is proportional to the strength of the received signal, so that this naturally increases as the target from which the echo is returned approaches the receiver. When other conditions remain the same, the amplitude of the echo is also a measure to some extent of the reflecting properties of the target, for example, its size; and an experienced observer may be able to guess the nature of the target from the echo pulse seen on the tube screen.

This measurement of the distance of the reflecting body responsible for the echo signals must be supplemented by a determination of the direction of arrival of the waves in both the horizontal and vertical planes, before the actual position of the reflector in space is completely known. These measurements can be made by well-established methods for observing the bearing or azimuth (ϕ in Fig. 6) and the angle of elevation above the horizontal (θ , Fig. 6). The first observation can be made by rotating the receiving aerial, which may at certain wavelengths be a horizontal dipole, about a vertical axis until the amplitude of the corresponding pulse decreases to zero; it is then known that the bearing is in line with the direction of the dipole. Alternatively, a pair of fixed aerials at right angles to one another can be used, connected to the field coils of a radio goniometer in the usual manner of a direction finder. Rotation of the search coil to the signal minimum position again enables the bearing to be determined.

The angle of elevation of the arriving waves can be measured by comparing the amplitudes of the voltages induced in two similar aerials mounted one above the other at a known distance apart, depending upon the wavelength in use and the range of angles of elevation it is desired to cover. This technique has been used for many years past by several investigators for measuring the angle of arrival of radio waves over long-distance communication paths, and it

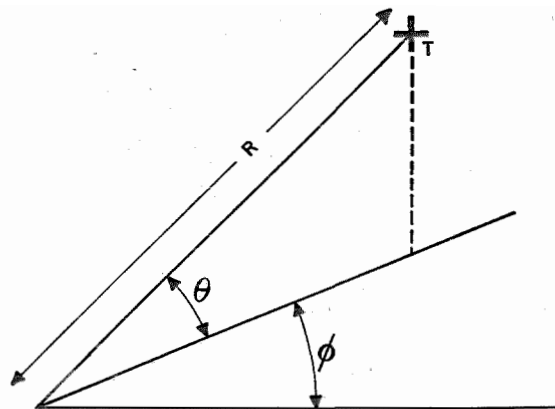

Fig. 6—The position of the target is defined by its range R , angle of elevation θ , and bearing or azimuth ϕ .

is directly applicable to the problem now under discussion. If the reflecting object being observed is an aircraft, then a knowledge of the range R and elevation θ (Fig. 6) enables the altitude at which the craft is flying to be determined. If the object of interest is a ship, then the angle of elevation is negligible, and the range and bearing determine its position.

The above considerations all apply to the use of wavelengths of the order of, say, 5 to 50 metres, for which the dimensions of the aerials are such as to make it impracticable to obtain very concentrated beams of radiation by the use of local reflectors. If, however, much shorter wavelengths are used, then it becomes possible to arrange what is, in effect, a radio searchlight,

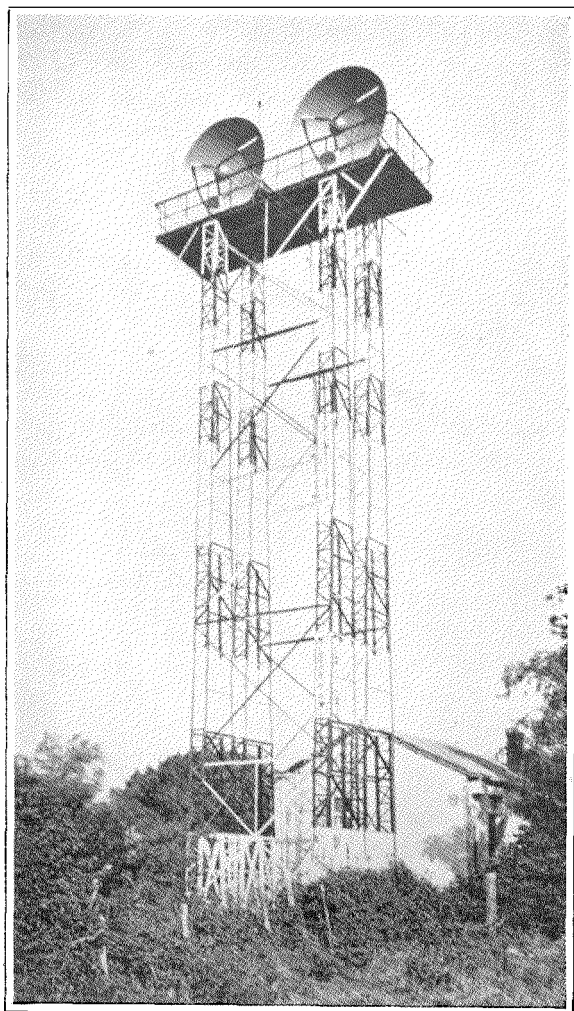

Fig. 7—Micro-ray tower (20 meters high).

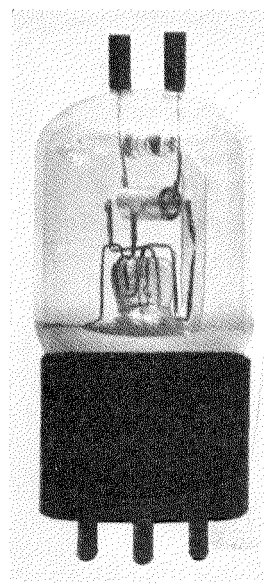

Fig. 8—Micro-ray oscillating tube.

but with the addition of the facility for determining distance. This type of equipment was used, for example, in 1931 in the radio telephony system which was set up for operation across the Straits of Dover between England and France, using a wavelength of 18 cm. and parabolic reflectors about 10 ft. in diameter. A combination of transmitter and reflector constructed on these lines, and moved together in both vertical and horizontal planes, is analogous to the searchlight and observer depicted in Fig. 2. When this type of radiolocation set is trained on the target to give the maximum deflection of the received pulse, the azimuth and elevation can be read off the horizontal and vertical scales respectively, while the range of the target is observed from the position of the pulse along the time-base on the screen of the cathode-ray tube.

This is the principle of the modern radiolocation set, in the development and exploitation of which so much technical and operational effort has been devoted in the past five years or so. The story of its success, and the technical details of its development must await description for the time being; but there is no doubt that the early establishment and use of Radar stations has contributed very materially indeed to both our defensive and offensive operations at various stages of the present war.

MICRO-RAY RADIO

Demonstration Across the Strait of Dover— March 31, 1931¹

A Micro-ray duplex telephone and telegraph link, first demonstrated successfully between Dover and Calais by the International Telephone and Telegraph Laboratories, Inc., of England and France, on March 31, 1931, was installed commercially between Lympne, England, and St. Inglevert, France, in 1933.

The Micro-ray system operated on a wavelength as low as 18 centimeters, required power of only one-half a watt, and employed transmitting and receiving antennas only two inches in length. Radiation emitted and received from the antennas was concentrated into very sharp beams by means of paraboloidal reflectors ten feet in diameter. The gain of these reflectors was of the order of 28 db at each end.

Production and Utilization of Micro-rays

The success of the 1931 demonstration gave some indication to engineers of the potential importance of centimeter waves in the general scheme of communications. Further, an order was received for a permanent link employing oscillator tubes with positive grids both at the transmitting and receiving ends and operating on 17.4 centimeters between the aerodromes of Lympne, England, and St. Inglevert, France (1933). This link was the first of its kind in the world and was used commercially until interrupted by the war.

The production and utilization of Micro-rays were described in 1933. Tube structure, the influence of the external circuit, the type of radiators and the principle of parabolic reflectors were discussed.² In 1934, the link itself, including the electro-optical system (transmitter and receiver units), micro-ray tube circuits, telephone and teleprinter equipment, was described in some detail.³ Micro-ray generators, receivers and aerial systems, also results of propagation measurements, were considered in 1936.⁴

Propagation Tests with Micro-rays⁵

Variations in signal strength had been noted on the 1,700 megacycle Lympne-St. Inglevert system. Extensive tests were undertaken between St. Margaret's Bay (England) and Escalles (France) during the latter part of July and the beginning of August, 1935, to ascertain the effect of a change of wavelength on the amplitude and frequency of the fading phenomena.

Propagation tests were made on three wavelengths (18, 20 and 29 centimeters). Computation showed that a combination of two wavelengths could produce signals remaining above 18 db

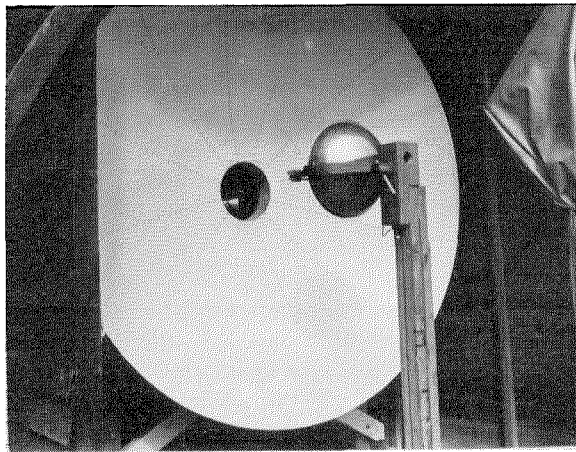

Fig. 9—Micro-ray transmitting reflector.

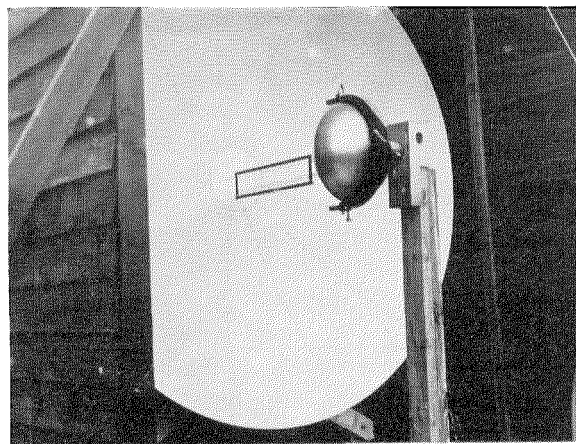

Fig. 10—Micro-ray receiving reflector.

¹ See References at end of article.

during the following time percentages:

- 18 cm.+20 cm.: 94% of the time;
- 18 cm.+29 cm.: 90% of the time;
- 20 cm.+29 cm.: 96.6% of the time.

Effects studied included tides in the English Channel, local interference (highly important) in front of the receiving reflector, atmospheric temperature, humidity and wind conditions. Of particular interest is the observation:

People walking along the cliffs caused very large sudden changes in the received signal strength. A similar effect occurred when ships were crossing the line of the beam at a certain distance. It can thus be inferred that an important part of the signal strength instability comes from the changes in the local interference pattern.

This observation, made in 1937, resulted from the experiments conducted in 1935. Since then, of course, immense strides have been made in the general field leading progressively to in-

creasingly ambitious developments of micro-ray systems, including the capability of indicating the position and shape of distant objects in the beam path.

References:

1. "Micro-Ray Radio," *El. Com.*, Vol. 10, No. 1, 1931.
2. "Production and Utilization of Micro-Rays," by A. G. Clavier, *El. Com.*, Vol. 12, No. 1, 1933.
3. "The Anglo-French Micro-Ray Link between Lympe and St. Inglevert," by A. G. Clavier and L. C. Gallant, *El. Com.*, Vol. 12, No. 3, 1934.
4. "Micro-Ray Communication," by W. L. McPherson and E. H. Ullrich, *El. Com.*, Vol. 14, No. 4, 1936.
5. "Propagation Tests with Micro-Rays," by A. G. Clavier, *El. Com.*, Vol. 15, No. 3, 1937;
- "Ultra-Short Wave Communication," by E. H. Ullrich, *El. Com.*, Vol. 16, No. 1, 1937;
- "Superheterodyne Reception of Micro-Rays," by A. H. Reeves and E. H. Ullrich, *El. Com.*, Vol. 16, No. 2, 1937.

Thomas Jefferson, himself a distinguished scientist, once spoke of the "brotherly spirit of science, which unites into one family all its votaries of whatever grade, and however widely dispersed throughout the different quarters of the globe."

Today, science has brought all the different quarters of the globe so close together that it is impossible to isolate them one from another.

Today we are faced with the pre-eminent fact that, if civilization is to survive, we must cultivate the science of human relationships—the ability of all peoples, of all kinds, to live together and work together in the same world, at peace.

—excerpt from the last speech prepared by the late President Franklin D. Roosevelt (April, 1945).

Development of Aircraft Instrument Landing Systems

By H. H. BUTTNER and A. G. KANDOIAN

Federal Telephone and Radio Laboratories, New York, N. Y.

Editor's Note: Aircraft and ground two-way radiotelephone communication and radio range systems of navigation—two fundamental contributions of radio to aviation—were achieved relatively early in the history of air transportation. A third contribution—instrument landing of airplanes—is reviewed in this paper. Work of major importance was done by Diamond and Dunmore of the U. S. Bureau of Standards in the years 1928–30. Since 1938, extension of their work to a practical conclusion has been the privilege of the Federal Telephone and Radio Corporation, a subsidiary of the International Telephone and Telegraph Corporation, with contributions from its associate companies. Recent experiences under actual operating conditions with numerous airport installations, both fixed and mobile, have produced extensive information on the effects of reflections of radio waves and their control in air navigation work. The complete practicability of the present instrument landing system has been confirmed. An engineering paper on this subject is being prepared by Sidney Pickles for early publication in this journal.*

DEVELOPMENT of navigational aids to facilitate landing of aircraft expeditiously during all conditions of low visibility has not kept pace with the rapid advances which have been made in aviation in the last twenty-five years. Commercial and military aviation will achieve its future potentialities only if complete independence of the weather can be realized so that saturation of traffic and confusion of schedules in periods of low visibility may be eliminated. Military operations on an extended scale require that large numbers of aircraft be able to take off from a fog-shrouded field, assemble above the overcast, proceed on their mission, return to the base, and land without extended periods of "holding."

That much progress has been made during the war on this problem, so vital to the future of aviation, has been revealed in an article by Lieutenant Colonel F. L. Moseley¹ describing the instrument landing system known as the SCS-51, adopted by the Army Air Forces as a standard, and now widely employed in its far-flung operations. The system was adopted following its successful demonstration and comparison with other systems in 1942 at Pittsburgh and other airports. At Bryan, Texas, one installation has more than 4,000 hours to its credit.

The SCS-51 is based on developments carried on by International Telephone Development Company between 1938 and 1941 at Indianapolis. This company later became a part of

the Federal Telephone and Radio Corporation, manufacturing subsidiary of International Telephone and Telegraph Corporation. The developments resulted in the so-called Indianapolis² or CAA-RTCA^{3,4} instrument landing system intended primarily for civil aviation applications.

The growth and progress of the art that led to the technique making the present system practical will be traced before describing the apparatus itself. In this connection the history of instrument landing presents an anomalous situation in which the completion of a system as a whole was retarded by the rapidity of development of its component parts. Whenever any landing system appeared to be on the verge of being adopted, new radio engineering concepts of promise appeared, and adoption was postponed to incorporate the new concept. A probable new and better arrangement was forever "around the corner" and no system was adopted in the U. S. A. until the imminence of war made further postponement unwise.

Early Developments

The problem of developing a dependable system to guide an airplane down on the runway for a successful landing under adverse weather conditions has occupied the attention of engineers and inventors since the first days of flying machines. Many ingenious conceptions were tried, including the use of powerful lights in the visible spectrum, infra-red rays, magnetic fields, and fog-dispelling chemicals. It was soon determined, however, that radio waves provided the most promising medium by which the

* Including a predecessor company, the International Telephone Development Company.

¹ See references at end of article.



Airplane used in flight testing the SCS-51 equipment.

operation of an instrument landing system could be made practical.

The early efforts to solve the complete instrument landing problem soon resolved themselves into three more or less separate problems, two of primary importance and the third of comparatively lesser difficulty and importance.

The first major problem is that of providing horizontal guidance to the pilot to enable him to locate the landing field and line up the airplane flight axis with that of the runway on which the landing is to be effected. This, in essence, constitutes the *localizer* problem.

The second major problem is that of providing vertical guidance to the pilot so that he may descend at a suitable glide angle to the point of contact. This is the *glide-path* problem.

The third problem, secondary to the above two in importance, is to provide *marker* beacons at fixed points along the course of the airplane to the landing field and to the point of contact. These marker signals act as landmarks to enable the pilot to check the path of the instrument approach at one or more well-defined points.

Various solutions were attempted for the *localizer* problem. One method involved the use of "leader cables" buried in the ground in and around the airport property. The airplane followed the magnetic intensity of the field from these cables. Another system involved fixed marker radiation from the ground, lined up with the runway, and direction-finding apparatus in the plane, to enable the pilot to line up the markers for horizontal guidance. All of these

systems, however, were unsatisfactory for various reasons.

By far the most important early development that contributed to the solution of the instrument landing problem was the radio beacon or range,⁵ developed for and installed on the civil airways for point-to-point flying in the middle twenties. These radio ranges operated at low frequencies (below 500 kilocycles) and established fixed courses by means of the familiar overlapping figure-of-eight radiation pattern. The well-known aural *A* and *N* interlocking modulation provided the course indication of the range. For *localizer* application, the two mutually perpendicular loops giving the overlapping figure-of-eight patterns were provided with the same carrier frequency but different modulation frequencies, which actuated two vibrating reeds in the airplane receiver to indicate relative amplitude of these two intensities. Equality of vibration of the two reeds defined the localizer course.

A really satisfactory *glide-path* system was not attained in the early stages of the art. One system obtained guidance from "leader cables" based on the inverse relation of the magnetic-field intensity with height but was subject to errors resulting from the banking and turning of the plane. Other systems were based on sensitive altimeters of the barometric, electrical, and sonic types. Each, however, proved faulty and made a reliable instrument landing system based on them unfeasible.

The marker-beacon arrangement at no time constituted a major problem and many feasible

solutions were proposed. All that is required is a vertical radiation at one given location. Actually the best marker beacons can be built at ultra-high frequencies for which directive antennas are most practical. However, even at frequencies as low as 3105 kilocycles, or lower, fairly satisfactory marker indicators have been developed.

Despite the aforementioned difficulties, by far the most serious of which was the glide path, instrument or "blind" landings were achieved successfully as early as 1929 by Lieutenant J. H. Doolittle (now Lieutenant General Doolittle) of the David Guggenheim Fund for the Promotion of Aeronautics. These landings were made in tests carried out at Mitchel Field. Lieutenant Doolittle's airplane carried, in addition to the radio aids outlined and the then-conventional aircraft instruments, an artificial-horizon instrument, a directional gyroscope, and a sensitive barometric altimeter graduated in 10-foot intervals. The artificial horizon at all times gave the attitude of the airplane with respect to the true horizon, and the directional gyroscope was employed first to find the localizer beam and then to maintain a straight course on the beam. The altimeter was utilized to determine height to the greatest possible accuracy by adjusting it to the field barometric pressure as reported by two-way radio; this instrument still had an error of 30 to 40 feet. The landing procedure, therefore, consisted of holding the airplane in a fixed angle of glide until contact with the earth was made, the landing gear taking up the shock.

Since commercial aeronautics then consisted largely of passenger travel, any landing system which did not provide a smooth and gentle landing was not considered feasible. It was accordingly determined that some means were required of ascertaining the absolute altitude of the airplane at all times during landing or, alternatively, positive guidance on the correct glide path down to the runway must be provided.

Diamond and Dunmore System

The Aeronautics Branch of the Department of Commerce at the Bureau of Standards began research on radio systems for instrument landing in 1928. These pioneering investigations are described in an enlightening paper by Diamond and Dunmore.⁶

A review of their work in the light of subsequent developments shows that a remarkable engineering advance was made in the instrument landing field through the efforts of this group in the short space of two years (1928-30). They produced the first complete radio three-dimensional instrument landing system. They investigated the separate problems of localizer, glide path, marker beacons, types of indicators for aircraft, and many related problems; they devised the equivalent of the present cross-pointer instrument for localizer and glide-path indication. They also introduced ultra-high frequencies (60 to 100 megacycles) and the use of sharply directive (beam) radiation patterns.

Although the ultra-high frequencies and the sharply directive patterns were used in an effort to establish an overlapping equi-signal type of glide path, these tests were not successful. Nevertheless, they gave rise to a fundamental discovery that resulted in the development of the constant-intensity type of glide path.

The constant-intensity type of glide path is based on the electromagnetic propagation characteristic of a source of radiation located near the ground. The constant-field-intensity lines from such a source form a family of parabolas directed outward and upward from the source, provided two conditions are met:

1. Only two waves of propagation exist, the direct and the ground-reflected wave. This condition was met by the use of ultra-high frequencies.
2. The ground is essentially a perfect reflector. This second condition is met satisfactorily only if horizontal polarization is used.

It is interesting to note that, in later work by other investigators, the Diamond and Dunmore type of glide path was attempted with vertically polarized radiation. The results were unsatisfactory, for with vertical polarization the nature of reflection from the ground changes markedly as a function of the vertical angle and also changes with the type of ground surface, buried cables, etc.

In the Diamond and Dunmore system, a localizer at 278 kilocycles—essentially similar to the radio ranges for point-to-point navigation—was used for horizontal guidance. The flight

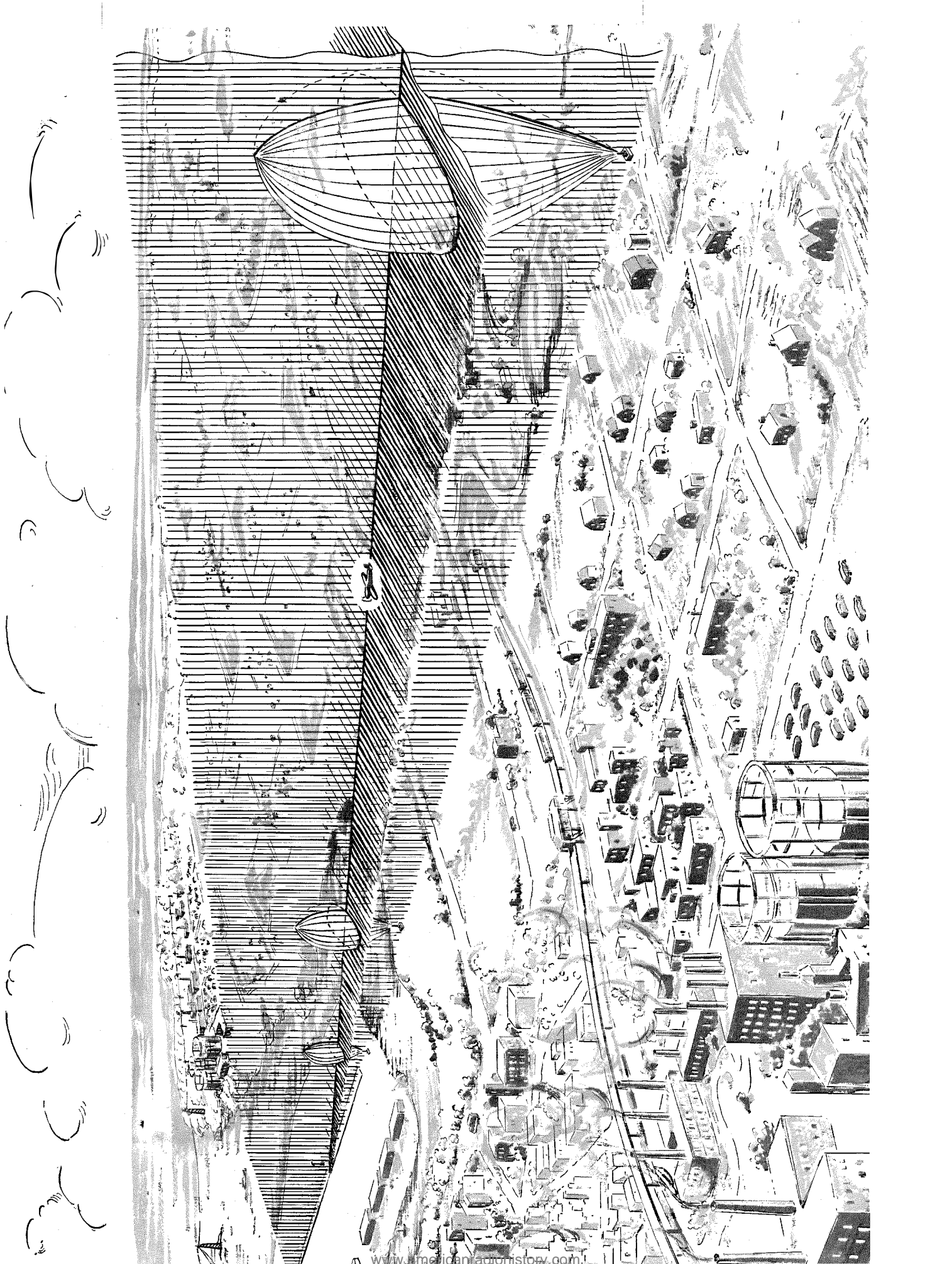

procedure was for the pilot to follow the localizer until a certain reading was obtained on the output indicator of his glide-path (90.8-megacycle) receiver. At this point he began his descent, always adjusting the rate to maintain a constant reading on the output indicator while still maintaining the correct localizer heading. With this procedure the airplane describes a parabolic curve to the point of contact on the runway. Marker beacons at 3105 kilocycles along the line of approach gave spot checks to the pilot. Thus the first complete three-dimensional radio instrument landing system was developed and proved feasible experimentally. It was a remarkable achievement and of great potential value to air navigation.

As in all early developments, however, elimination of certain faults and unknown factors still required intensive study and engineering consideration. Some of these shortcomings were in the localizer. The course was too broad since sharp radiation patterns at low frequencies are not practicable. Further, in the region at right angles to the main localizer course, there was a considerable amount of uncontrolled radiation which could confuse the "lost" pilot and give actually misleading and potentially dangerous indications. Then again, because of the low frequency, the course was somewhat subject to bends and apt to split into multiple courses. Furthermore, it was far from static-free.

Another localizer problem requiring solution was that of obtaining two independent radiations of a single carrier frequency, each modulated at a different frequency but always maintaining their intensity ratios constant. All tube modulation schemes involved the inherent difficulty of changing levels with tube aging and failure. This meant that the course, depending for its stability on the ratio of the two modulations, would not remain fixed.

The glide path on the other hand had one inherent fault, i.e., its parabolic shape. It was too steep at the beginning of the glide, a few

miles away from the point of contact, and too shallow near the landing field. This meant that, even if all obstructions were sufficiently cleared to allow the shallow approach into the landing field, the pilot while attempting to follow the localizer course and attending to the various instruments and controls in the aircraft, must also more or less continuously adjust his rate of descent—an obviously major disadvantage.

Another difficulty with the constant-intensity glide path was the necessity for a very stable receiver since any change in sensitivity during the landing operation would result in a severe kink in the "glide path" at a potentially very dangerous time. Moreover, if a system of this type were standardized, the sensitivity of the receiver must remain fixed for all installations, in different airplanes and airports, otherwise no uniformity of landing could be maintained. An alternative would be to check the sensitivity calibration of the receiver against an altimeter while over the outer marker; but this would necessitate reliance on the altimeter which itself is subject to inaccuracies.

Period of Experimentation

From this very productive period of useful and rapid developments at the Bureau of Standards by Diamond, Dunmore, and others, until late 1937 many instrument landing tests and experiments were made in all parts of the United States and Europe. Most of these experiments were based on the Bureau of Standards system but were made by groups somewhat independent of one another and not always with adequate co-ordination. A clear engineering understanding of the problem was not evident.

The Department of Commerce made installations and tests between 1930 and 1933 in Newark, New Jersey, and Oakland, California, as well as in College Park, Maryland.

At Wright Field in 1932-33, the Army Air Corps continued to favor the direction-finding system of orientation including the use of a sensitive altimeter for control of the descent path.

Transcontinental and Western Air, Inc., made an installation using a frequency of 85 megacycles at Kansas City Airport in 1935. Difficulties inherent in vertically polarized constant-intensity glide paths were encountered.

The illustration on the facing page is a pictorial representation of a typical localizer—glide-path—marker instrument landing system as developed by the Federal Telephone and Radio Corporation and standardized by the Civil Aeronautics Administration, the U. S. Army, and the U. S. Navy. The vertical pattern is the equi-signal localizer plane and the horizontal pattern is for the glide-path plane. An airplane is shown between the outer and middle marker beacons on an approach for a landing.

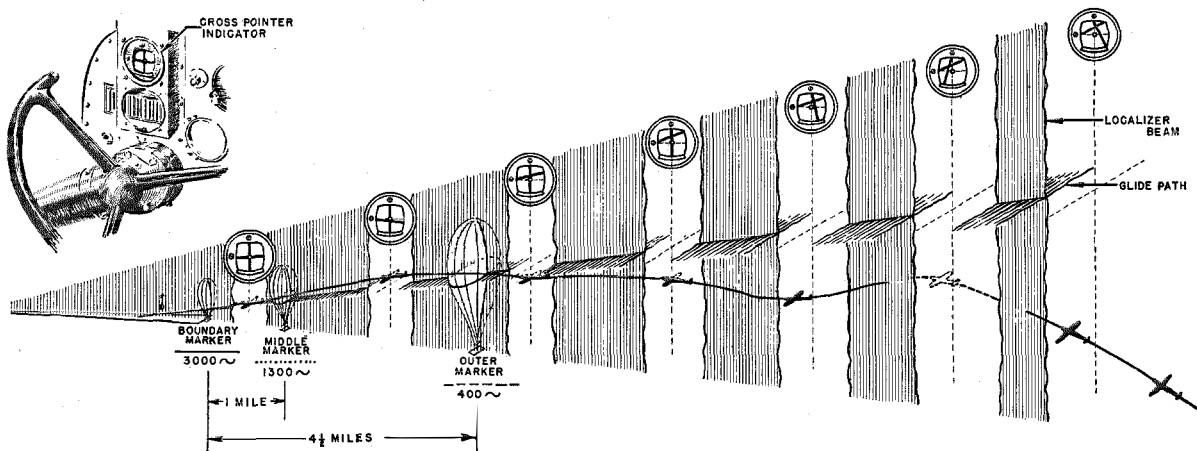

One path of an airplane in making an instrument approach. The airplane first "brackets" the localizer course. The pilot always turns the airplane to the direction in which the cross-pointer indicators deviate. While continuing to maintain localizer alignment, the airplane then "follows" the glide-path pointer. The marker beacons are known check points along the glide path.

In 1935 the Bureau of Air Commerce began to consider the development of a satisfactory modulation scheme for the localizer and also gave consideration to the advantages to be gained by using an ultra-high frequency both for the localizer and the glide path.

The Washington Institute of Technology in 1935 completed a ground equipment based on the Bureau of Standards system except that it was installed in trailers to enable quick transportation around the airport to accommodate changing wind directions. Difficulties inherent in low-frequency localizers were again encountered. However, a mechanical modulation method was developed to allow two independent modulations of a common carrier frequency so that the course would not be thrown off by tube aging and variations. Considerable objectionable cross modulation existed between the two channels, but independence of the course from vagaries of tube operation was achieved.

The Bendix organization, in co-operation with United Air Lines, made several tests and installations in 1936-37. Their system too was based on the work done by the Bureau of Standards but used a combined localizer and glide path at 91 megacycles. The system was usable to the extent that, with the installation at Oakland, California, hundreds of hooded landings were made on an experimental basis. On other installations at Cleveland, Newark, etc., the results were not so good. As a system, several inherent weaknesses were present, for example, the local-

izer radiation was not controlled except in the region of the course. Thus a "lost" pilot could pick up dangerous and misleading indications while circling in a fog to orient himself. Further, the shape of the glide path of this system was not satisfactory.

Some experimental work on ground and aircraft installation of ultra-high-frequency instrument landing equipment was done at Fort Worth, Texas, by American Airlines.

Meanwhile in Europe considerable work was being done. George Perroux, whose tragic death occurred just before the liberation of France, contributed, in co-operation with J. L. Lair, a number of important inventions to this field. R. Elsner and E. Kramar developed a two-course 33.3-megacycle vertically polarized radio range and adapted it to instrument landing by using the constant-intensity lines of the radiated field for the glide path, as in the Diamond and Dunmore system.

A complete system of this type was installed and tested in the U.S.A. at Indianapolis, Indiana, in 1937 by International Telephone Development Company, predecessor of Federal Telephone and Radio Corporation. Flight tests indicated that the course was too broad, and the inevitable difficulty was encountered with the glide path because vertical polarization was used. However, the localizer did provide horizontal guidance over the complete 360-degree azimuth; the overlapping patterns making up

the localizer course gave the correct signal in all directions.

Thus during this period of 1930-37 many systems were installed, nearly all being variations of the Diamond and Dunmore Bureau of Standards system. Some were found to be fully operative and some were not, although any one of them was better than no system at all for limited-visibility and low-ceiling conditions. However, no system was adopted for widespread usage because of the tendency to await a "better" system.

Summing up the status of the instrument landing in the period of 1930-37, it can be stated that:

1. Many engineering problems were not fully understood and therefore were not solved.

2. Pilots of that period were not sufficiently trained on any one system to utilize it to the maximum extent.

3. Since a primary consideration of commercial airlines was passenger comfort, a smooth and gentle landing was an essential requirement. Under peacetime conditions, airlines always had the choice of flying or cancelling a trip if weather conditions were unfavorable. If a trip were started and the destination field became closed by low ceiling and visibility, the pilot could terminate the flight at another airport. Under these circumstances, instrument landing was seldom compulsory; it was considered more advantageous to arrange flights so that all landings would be contact rather than to rely on a landing system that might disturb the comfort of passengers and cause them to prefer other methods of travel.

Under military conditions, flying is not optional but is dependent on the unpredictable needs of war. Hence landings must be made when necessary almost regardless of weather.

RTCA Recommendations

Late in 1937 the Radio Technical Committee for Aeronautics, a co-ordinating group representing airlines, manufacturers, and various interested government agencies, surveyed the status of instrument landing systems and drew up certain recommendations. Based on these recommendations the Bureau of Air Commerce (later the Civil Aeronautics Authority) drew up de-

tailed specifications for the development of an instrument landing system which would contain the best features of all the various systems previously tested. This system then was to be installed and tested at the Indianapolis Municipal Airport. The contract for this development was awarded to the International Telephone Development Company and work was begun in the summer of 1938.

It is instructive to review briefly the features of the recommendations of the Radio Technical Committee for Aeronautics and the Civil Aeronautics Authority's specifications which were significant from the engineering development standpoint. They will give a fair picture of the state of the art at that time.

For the runway localizer, a choice between horizontal or vertical polarization was not made. It was still undetermined as to which was more suitable for this application. Though a 360-degree indication was required to give correct information to the pilot regardless of his orientation with respect to the localizer, no known method existed at the time for providing such a two-course localizer with horizontal polarization.

Though an ultra-high frequency of 108 to 112 megacycles was specified for the localizer, the course sharpness established by the radiation pattern was considered satisfactory at 0.5 decibel per 1.5-degree deviation from the course path. This gave a course no more sharply defined than the low-frequency radio ranges and localizer previously tried and thus nullified to a great extent the potential advantage of the ultra-high frequency. The first reason was that the full importance of course sharpness and accurate course definition, and their effects on multiple courses and course bends was not appreciated. Secondly, in the then-existing state of the art, no localizer systems were known which could give 360-degree coverage and still provide a sharply defined course in excess of 0.5 decibel per 1.5 degrees.

The localizer course was to be established by overlapping radiation patterns, modulated by 90 and 150 cycles, respectively. How to obtain two independent modulations of a single carrier so that under no reasonable circumstances would their ratios change, and thus affect the established course, was not then known. Existing methods had yielded an objectionable degree of

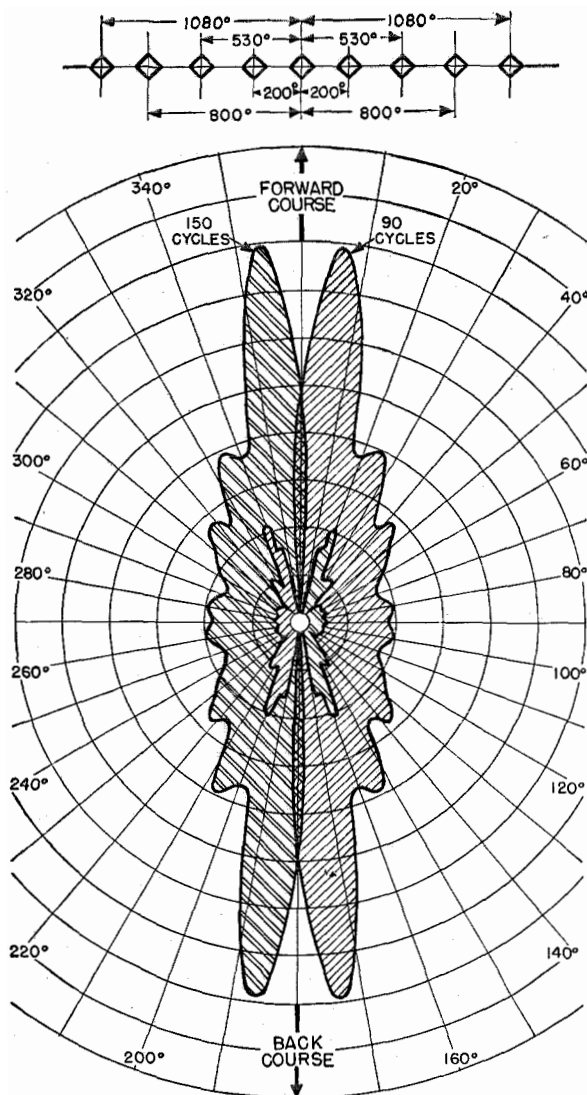

Typical two-course localizer radiation pattern for a Civil Aeronautics Authority installation. The antenna array consists of nine loops, each of which participates in the production of both the 90- and 150-cycle overlapping patterns.

cross modulation between the two channels and a large amount of distortion.

In general, also, no clear ideas existed as to proper choice of localizer site, how reflections cause bends and multiple courses, and what caused so-called "pushing" of the course (apparent displacement of the course depending on aircraft orientation and approach direction). The lack of full appreciation of these phenomena prevented an accurate diagnosis and solution of the problems.

The glide-path problem at this time had not advanced beyond the original system of Diamond and Dunmore although the desirability of an improved glide path was evident.

The marker beacons were transferred to 75 megacycles and effected a considerable improvement over the low frequencies used by Diamond and Dunmore.

Glide-Path Developments

Two significant developments proved helpful during this period. One from Kramar involved a modification of the Diamond and Dunmore system of constant-intensity glide path, whereby some control over the shape of the path could be effected. It was to be accomplished by displacing the glide-path antenna from the center line of the runway so that an appreciable horizontal angle would be subtended by an airplane coming in for a landing, i.e., from the beginning of the glide path to the point of contact. By proper control of the horizontal pattern of the glide-path antenna, more or less energy could be directed at different points along the glide path to straighten somewhat the normal parabolic landing path, not over the complete glide but from approximately 600 feet down.

The other development covered an equi-signal type glide path with overlapping radiation patterns, and was tried out in 1938 by D. M. Stuart and J. C. Hromada of the Civil Aeronautics Authority. Two sources of radiation above ground, one higher than the other, were used with a common carrier frequency but different modulation, similar to the localizer. The radiation sources, because of their differing heights above ground, formed overlapping lobes in the vertical plane, and the lowest of these equi-signal intersections could be used as a glide path. An essentially straight-line glide path was obtained.

While the fundamental idea was sound, several difficulties became apparent and eventually tests were discontinued. One of the difficulties was that the lowest glide angle was still too high (over 5 degrees) mainly because the 90-megacycle frequency used was too low. Another problem was that the pole on which the antenna system was mounted constituted quite a hazard unless it were far removed from the center line of the runway. If it were removed too far, however, it

further complicated an already complex problem of controlling the point of contact.

The Indianapolis System

The engineers of the International Telephone Development Company, in undertaking the development of an instrument landing system to technical specifications of the Civil Aeronautics Authority (based on recommendations of the Radio Technical Committee for Aeronautics) were thus confronted with not only a straightforward engineering problem such as the design and installation of ultra-high-frequency transmitting, receiving, and antenna equipment, but also many complex problems for which no practical solution had been proposed. A group of these engineers, under the direction of A. Alford, began a systematic analysis and research in an effort to find engineering answers to the difficulties which had until that time kept instrument landing of airplanes "around the corner." This group thus became responsible for a great deal of fundamental engineering progress which had been lacking in this field since the early work of Diamond and Dunmore.

Some of the problems involved experiments to determine the relative merits of vertical and horizontal polarization. The evidence was predominantly in favor of horizontal polarization when essentially pure polarization was used. Of fundamental importance also was the study of reradiation from various objects around the airport, how they affected the course, caused multiples and bends, and what could be done to remedy the situation. A description of some of these experiments and equipment used by the International Telephone Development Company engineers is included in two publications.^{3,4}

A few of their developments have had a far-reaching significance on the instrument landing art. One was the omnidirectional horizontally polarized antenna, the ultra-high-frequency loop.^{7,8} This type of antenna, because of its substantially pure horizontal polarization, could be used in localizer antenna arrays and establish a course essentially free from "pushing." Another major advantage of the ultra-high-frequency loop antenna resulted from its omnidirectional radiation characteristic. In the past nearly all horizontally polarized arrays, as for example the Bendix

localizer, were made up with dipoles. A dipole has zero radiation along its axis. As a result, in the beacon or localizer applications, no signal was radiated in these directions; thus an airplane flying in these regions either received no signal or, worse, picked up whatever miscellaneous signal may have been reradiated to that region. This, of course, was very dangerous. With the use of loop antennas, however, arrays of three or more loops were devised with overlapping patterns which gave correct signal indication in all directions, complete 360-degree coverage in the azimuth.

In fact this type of localizer beacon array was eventually expanded into a more general type of symmetrical directive localizer array⁹ which allowed, with the addition of more loop elements, any degree of course sharpness and directivity. Thus course sharpness of 6 or more decibels per 1.5-degree deviation from the course line became a practical reality, and is now being used in Civil Aeronautics Administration installations.¹⁰ It is noteworthy that this is more than ten times as sharp as required by the original specifications.

Another very important development at this time was the application of the Alford transmission-line bridge circuit in the localizer and radio range circuits.^{11,12} The use of the bridge circuit in conjunction with the arrays mentioned above made it possible to obtain two overlapping beacon patterns simultaneously, each one modulated with its characteristic modulation frequency, in most cases 90 and 150 cycles. The importance of this scheme in stabilizing and making the overall system reliable cannot be overemphasized. Since each loop in the array participated equally in each of the overlapping patterns (90 and 150 cycles) it followed that any defect or damage in any part of the array affected the two patterns *equally* and hence the ratio of the two field strengths remained constant. The course thus remained remarkably stable and reliable.

The transmission-line bridge circuit had another extremely important use. This was in the mechanical modulator. This modulator took the radio-frequency output of the crystal-controlled transmitter and, dividing it in two independent channels, modulated each at 90 and 150 cycles, respectively. With the use of the bridge circuit, the cross modulation was completely eliminated.

The overall distortion was very small, in most cases well below 10 percent. Thus, there was developed for the first time a completely satisfactory system which stabilized the localizer course against any defects in the radio-frequency transmitter, including the aging and failure of tubes.

In the case of the glide path, the Kramer variation of the Diamond and Dunmore system was tried. A reasonably straight glide path was obtained from the outer marker, at 500 feet altitude down to the point of contact. During demonstrations to the Radio Technical Committee for Aeronautics and various airline pilots, opinions differed considerably as to the value of this modification. The consensus was, however, that the straight-line portion of the glide path should begin at a higher altitude (1500 feet at a distance of six miles) and should continue down not to ground, but to approximately 100 feet where it should shallow off to strike the ground at an angle of between one and two degrees. The commercial pilots definitely did not want a straight-line glide path down to the point of contact because they felt contacting the ground at anything over 2 degrees would not be satisfactory for commercial passenger traffic.

After due consideration of the problem, a suitable antenna array was devised to provide the recommended glide path which was set up at Indianapolis; flight tests showed that it met all the requirements.

However, there still were serious limitations to the constant-intensity type of glide path. It required ingenuity and careful adjustment at each airport installation because the glide-path antenna system had to be so far away from the runway that various natural and artificial obstructions prevented straightforward propagation from the antennas. Control of the glide path above 1500 feet was virtually impossible for most of the installations. Also, most pilots, particularly for military purposes, wished to start their constant rate of descent from 5,000 feet, 10,000 feet, or even higher altitudes continuing to the point of contact. These disadvantages and the necessity of maintaining fairly constant sensitivity of the glide-path receiver, emphasized the need of a fundamental improvement in the glide-path system.

Alford suggested that if two loops were used on a vertical pole, one set at approximately one-half wavelength and the other at a large number of wavelengths above ground, an equi-signal glide

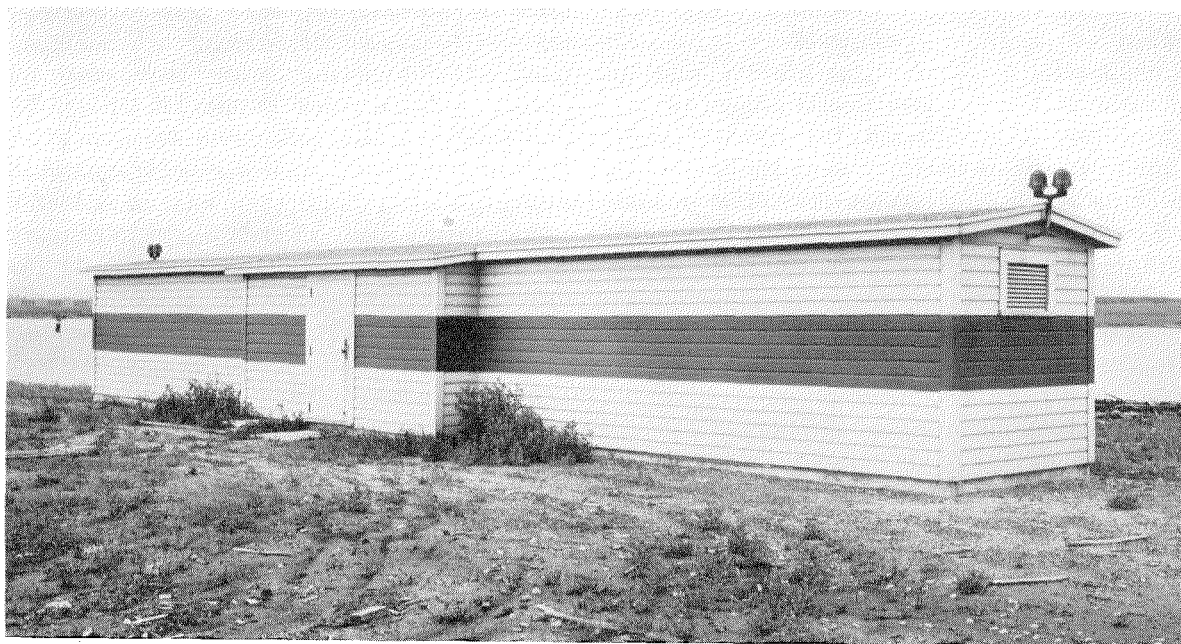

Localizer housing for a Civil Aeronautics Authority instrument landing installation.

path could be obtained in the form of a cone with its apex at the antenna pole. If the pole were displaced from the runway, the localizer course would cut a plane parallel to the axis of the cone and give a hyperbolic intersection. The glide path would provide a constant rate of descent from any desired height, but near the runway point of contact the curve would flatten out, as in a hyperbola. Furthermore, by adjusting the horizontal pattern of the top radiator, with respect to the bottom radiator, considerable control could be obtained over the point of contact.

An important question was the choice of frequency to be used for this type of glide path. Calculations showed that any frequency below 300 megacycles would make the top antenna so high that the supporting structure would constitute a serious hazard to flight. On the other hand, at very much higher frequencies conventional tubes, techniques, and commercial components would not be suitable. Thus, it was decided to use 330 megacycles because the crystal-control drive units used for localizers at 110 megacycles could be used to triple in frequency to 330 megacycles.

Thus began the work on the equi-signal type of glide path which has proved of great value both for military and commercial aviation.

Aircraft Installation and Antenna

The basic philosophy of this instrument landing system was to have all the complex equipment on the ground, establish the correct landing path in space, and require a minimum of equipment in the aircraft. This minimum equipment consisted of a crystal-controlled superheterodyne type receiver^{3,4} for the localizer and glide path, a cross-pointer indicating instrument, and the antenna system. The marker receiver was already standard commercial aircraft equipment for radio range use.

It was desirable to use a single antenna both for the localizer at 109.9 megacycles and the glide path at 93.9 megacycles. This problem was solved by the use of a small two-element Alford loop and tuning means whereby the operation of the two receivers was possible without mutual reaction.¹³

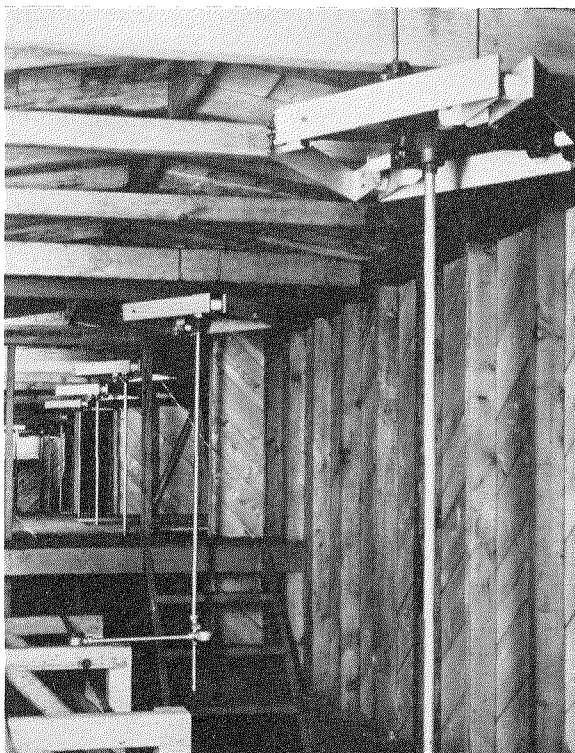

Interior view of the localizer house for a Civil Aeronautics Authority installation.

Microwave Developments

During the time that the International Telephone Development Company was engaged on these projects, considerable interest was aroused in the use of microwaves for instrument landing. The development of the Klystron high-frequency generator gave added impetus to this subject. A group under Professors E. L. Bowles and W. L. Barrow at Massachusetts Institute of Technology directed a project referred to as the microwave instrument landing system. This investigation disclosed interesting properties of the proposed system and served greatly to advance microwave technique in general. The Sperry Gyroscope Company at the same time devoted considerable attention to the development of a 3,000-megacycle instrument landing system.

Bush Committee

In October, 1939, a meeting of a conference group of the National Academy of Sciences headed by Dr. Vannevar Bush was held at Washington. The group convened in response to a



Army-type mobile localizer, SCS-51, manufactured by Federal Telephone and Radio Corporation. The antenna array consists of three main radiating loops and an auxiliary pair to increase the course sharpness.

request of the President of the United States that the Academy study the problem of standardizing instrument landing systems. A thorough and complete survey of projected and existing systems was made.

The group recommended the adoption of the so-called Indianapolis system. There was general agreement that this system was completely operative and practical in its fundamental elements of localizer, glide path, and marker beacons.

Further recommendations were made as follows:

1. Instrument landing systems should be standardized and should consist of localizer, glide path, and marker beacons.

2. Approximately 10 installations of the Indianapolis system (Federal Telephone and Radio Corporation) should be made throughout the

country for further development and pilot training. The installation should be such as to allow modification readily from the available (constant-intensity) glide path to an improved type capable of furnishing a larger and straighter glide path (equi-signal type).

3. Development of microwave equipment should be expedited in order that it might undergo field tests under service conditions.

4. Further intense study should be given to indicating instruments other than the cross-pointer type before standardization.

5. Since fixed equipment is suitable for civilian needs, while military use necessitates portable equipment, it was recommended that fixed equipment should be installed of such a nature that portable equipment to duplicate its performance could be built when necessary.

Development of SCS-51

With the development of World War II, the need for instrument landing equipment for military application became very acute. Except for the constant-intensity glide path, the Indianapolis system developed by Federal for the Civil Aeronautics Authority was considered satisfactory, provided equivalent portable equipment could be made that would meet Air Corps service requirements. Such specifications were agreed on mutually by Federal Telephone and Radio Corporation engineers and Wright Field personnel under Lieutenant Colonel F. Moseley.

It was agreed that only the equi-signal type of glide path would be satisfactory for military application. Such a unit was completed in 1942, along with a portable localizer and all other elements of the instrument landing system.

The complete system was demonstrated to Army, Navy, airline, and Civil Aeronautics Administration personnel at Pittsburgh, Pennsylvania, in the fall of 1942. At the same time various other systems were demonstrated and flight tested. After these tests and many others in various other airports in the country, the Federal Telephone and Radio Corporation instrument landing equipment was officially adopted by the Army. The primary reasons for this choice were:

1. The transmitting equipment was more sturdy and reliable than that of others, was compact, and easily transported and set up.
2. The airborne receiving equipment was light and compact.
3. The equipment made as much use as possible of well-known radio components, thereby providing for manufacturing efficiency and also for ease of servicing and repair in the field without highly specialized personnel.

An instructive article on the SCS-51 has appeared recently in *Air Force*,¹ the official journal of the Army Air Forces.

Future Trends

With the years of experience in commercial-field instrument landing and the added experience gained in military applications in recent years, there is little doubt that instrument landing by radio will necessarily have a very definite and vital place in future aviation. It is hard

to conceive of air transportation on any scale without widespread and well-co-ordinated instrument landing systems. This means that there must be numerous installations of such equipment and a well-directed plan of pilot training—for even the best system cannot be properly used, in fact can be dangerous, without experienced pilots well trained in its use.

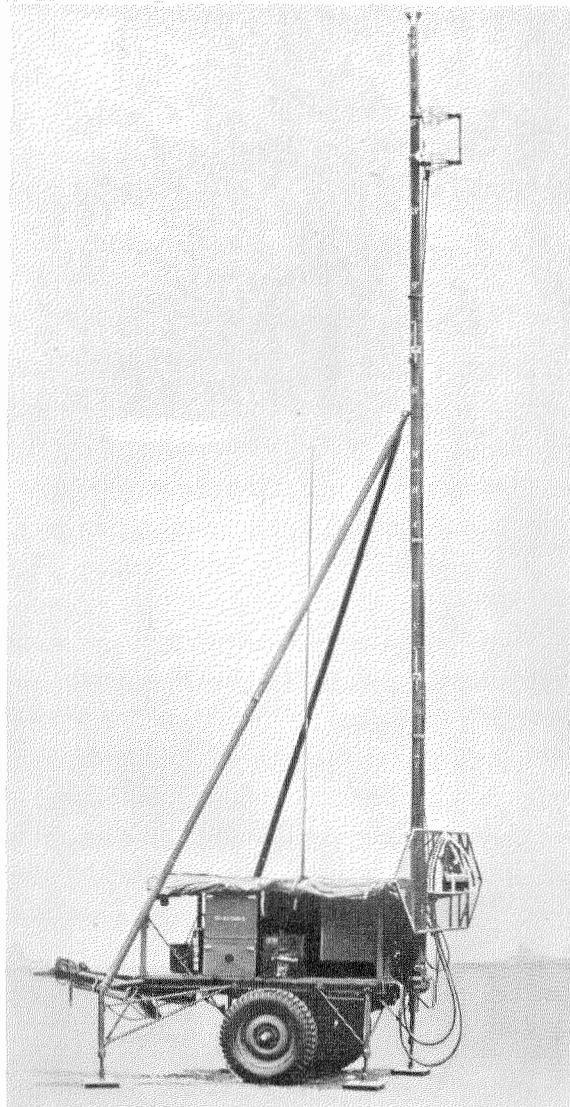

Federal Telephone and Radio army-type glide-path equipment in operating position. The top pair of radiators gives the lower radiation pattern and the lower antenna provides the upper radiation pattern, the intersection of which forms the equi-signal glide-path course.

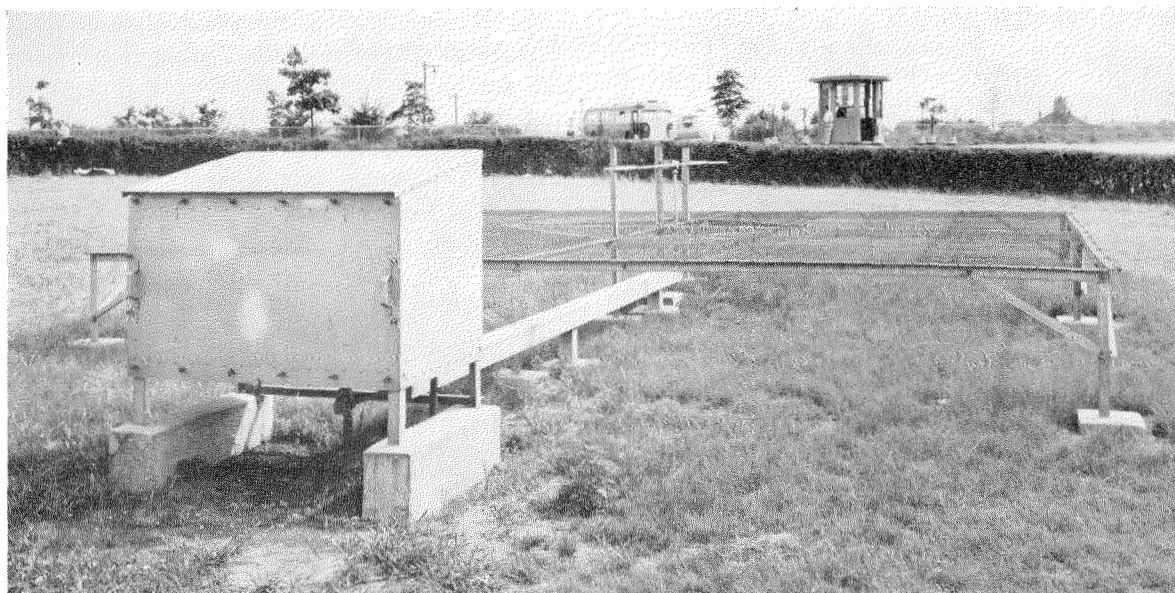

Civil Aeronautics Authority marker-beacon installation.

There has been one underlying trend in all instrument landing work, and that is complete automatic operation. Fundamentally, of course, the principle is sound. The localizer beacon, located on the ground, actuates a pointer which, when interpreted properly by a human pilot and followed quickly and accurately, provides horizontal guidance. The glide-path beam, again located on the ground, working through the receiver in the airplane, actuates another pointer which indicates to the pilot what is to be done for vertical guidance in landing. There is, therefore, no reason why the signals to these pointers cannot actuate an automatic pilot, which can react more rapidly and unerringly than any human pilot. Thus, in the not-far-distant future, all landings, in good weather and bad, will be automatic.

References

1. F. L. MOSELEY, "Shooting Landings by Radio," Air Force, vol. 27, p. 41, October, 1944.
2. "Report on Instrument Landing System," *Civil Aeronautics Journal*, vol. 1, February, 1940.
3. JACKSON, ALFORD, BYRNE, AND FISCHER, "The Development of the Civil Aeronautics Authority Landing System at Indianapolis," *Electrical Communication*, vol. 18, p. 285, April, 1940; and *Trans. Amer. Inst. Elec. Eng.*, 1940.
4. H. I. METZ, "The C. A. A.—R. T. C. A. Instrument Landing System," U. S. Department of Commerce Technical Development Report No. 35, October, 1943.
5. J. H. DELLINGER and H. PRATT, "Development of Radio Aids to Air Navigation," *Proc. I.R.E.*, vol. 16, p. 890, July, 1928.
6. H. DIAMOND and F. W. DUNMORE, "A Radio Beacon and Receiving System for Blind Landing of Aircraft," *Bureau of Standards Journal of Research*, 1930; also *Proc. I.R.E.*, vol. 19, p. 582, April, 1931.
7. A. ALFORD and A. G. KANDOIAN, "Ultra-High Frequency Loop Antennae," *Electrical Communication*, vol. 18, p. 255, April, 1940; and *Trans. Amer. Inst. Elec. Eng.*, 1940.
8. A. ALFORD, U. S. Patent 2,283,897.
9. A. G. KANDOIAN, U. S. Patent 2,283,677.
10. P. CAPORALE, "C. A. A. Instrument Landing Systems," *Electronics*, vol. 18, February and March, 1945.
11. J. GOLDMANN, U. S. Patent 2,251,997.
12. A. ALFORD, U. S. Patent 2,244,756 and 2,147,809.
13. A. ALFORD, U. S. Patent 2,259,510.

Special Aspects of High Frequency Flexible Balanced Cables

By N. MARCHAND

Federal Telephone and Radio Laboratories, New York, N. Y.

Summary: This paper discusses the construction of a number of different types of solid dielectric flexible balanced cables, some advantages and disadvantages in their use, and a number of testing methods that have been used in their production.

THE modern type of HF balanced cable consists of two conductors symmetrically disposed so that when equal and opposite voltages are impressed upon the input to the cable, equal and opposite voltages will be obtained at the output. If the voltages are equal and opposite at the input and are not equal and opposite at the output, they are said to be unbalanced.

In some cases the balanced cable consists of two conductors symmetrically placed in a common circular shield and kept in position by spaced insulating supports. However, if the two conductors are immersed in a dielectric of suitable properties which completely surrounds them and fills up the interior of the shield, an excellent UHF low loss flexible cable may be obtained. One such type of cable, manufactured by the Federal Telephone & Radio Corporation, is shown in Fig. 1A. For very highly balanced cables, it is found more expedient to use two coaxial cables bound together by means of a third shield (Fig. 1B). This extra shield keeps the two coaxial lines firmly together and insures equality of length. At lower frequencies, this disposition also aids in shielding the cables from external interferences. While excellent for highly balanced needs, the cable must be handled quite carefully. Another type of cable, consisting of two coaxial cables twisted together, is shown in Fig. 1C.

For low frequency work, a 200-ohm, unshielded, balanced cable is available (Fig. 1D). This type of cable is used where balance is not critical, such as for an antenna lead-in.

Causes of Unbalance

The equilibrium conditions for balanced cables, previously discussed by the author,¹ determine the currents that must flow on the transmission

lines in order to avoid unbalance. In Fig. 2 is shown a shielded transmission line with its resultant line currents, I_1 and I_2 , equal and opposite currents; I_3 is the shield current and I_0 , the outside extraneous current. When no unbalance exists, I_3 will be 0, and I_0 will not couple into I_2 or I_1 . When I_3 is not 0, I_1 is not equal and opposite to I_2 and their unbalance must be removed by a balanced termination which will not necessarily yield a correct result.

It can be seen that there is an intricate relationship between the balanced currents and the shield currents. Any change in the dimensions of the cable, wherein one conductor is made unsymmetrical with respect to the other, will introduce unbalance. To avoid this unbalance, extreme care must be exercised in the construction of balanced cables. Any bending of the balanced transmission line in the plane of the two wires may cause unbalance inasmuch as it will force one wire against the shield under compression and pull the other wire away from the shield under tension. A good dielectric will tend to minimize without eliminating such a result.

It has been found that when two coaxial transmission lines are bound together in a common shield, as shown in Figs. 1B and 1C, the cable balance is excellent. Fig. 3 illustrates end and side sections of such a combination. Here the current I_1 is again equal and opposite to the current I_2 with their return currents I_3 and I_4 flowing on the inside of the shield. The two currents in this case are independent; it is only in the very low frequency range that a very small extraneous coupling takes place through the shields. When surge impedances equal to those of a dual type of balanced cable are desired, the outer dimensions of the cable obviously become relatively large, but the results will warrant its use. It should be noted that the foregoing discussion applies also to the twisted double coaxial balanced type of cable.

¹See reference at end of article.

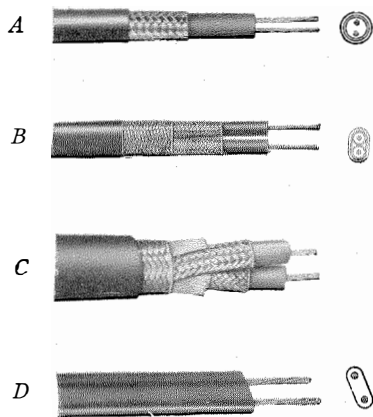

Fig. 1—Balanced cables.

- A—Dual balanced cable.
- B—Straight double coaxial balanced cable.
- C—Twisted double coaxial balanced cable.
- D—Unshielded lead-in dual cable.

Unbalance in these types of cables is introduced by two different effects. Assume that two equal and opposite voltages are impressed: E and $-E$, respectively, on each of the conductors. The currents received at the far end, if the lines are properly terminated, will be

$$I_1 = \frac{E}{Z_{01}} e^{-\alpha_1 L_1 - j\beta_1 L_1}$$

$$I_2 = -\frac{E}{Z_{02}} e^{-\alpha_2 L_2 - j\beta_2 L_2}$$

where the subscripts refer to the conductors 1 and 2; Z_0 is the surge impedance, α the attenuation constant, β the phase delay, and L the total length of each conductor. It can be seen from these two equations that any variations in Z_0 , α , β , or L will introduce unbalance.

Z_0 variation results from changes in the size of the cable caused by imperfections in the extrusion of the dielectric or differences in tension on the shield when it is applied. Variations in α , the attenuation constant, usually result from variations in materials. The variations in β also are caused by changes in size and materials. It is the variation in total phase shift due to variations in length and β that cause the greatest trouble, since the attenuation factors are usually negligible by comparison. The variation in length may be an actual difference in length, but it is

more often caused by bends and twists during construction or use of the cables. It is only through the application of an appropriate manufacturing technique and the exercise of very great care that such defects can be avoided and properly balanced cables obtained.

Frequently, the requirements call for equal and opposite output voltages and, also, for balanced input impedances. Considering unbalance from the input end brings in still another factor, i.e., reflections caused by minor discontinuities in the line itself. Each variation at a point s distance from the input end, will cause a small reflection factor ρ_s . This means that at the ρ_s input end, the total reflected voltage will be

$$E_{\text{Total reflected}} = \sum_{s=0}^{s=L} \rho_s E e^{-2\alpha s - j2\beta s}$$

where E is the input voltage.

Thus, if any discontinuity is present in both lines in an equal amount at equal distances from the input end, the input would still be balanced, but this coincidence would be rare. Usually the

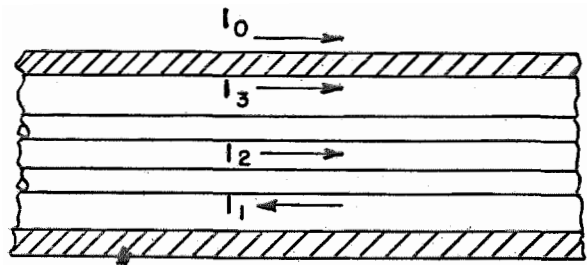

Fig. 2—Balanced transmission line currents.

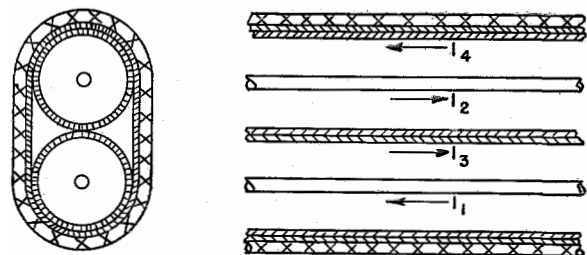

Fig. 3—Balanced transmission line made up of two coaxial cables.

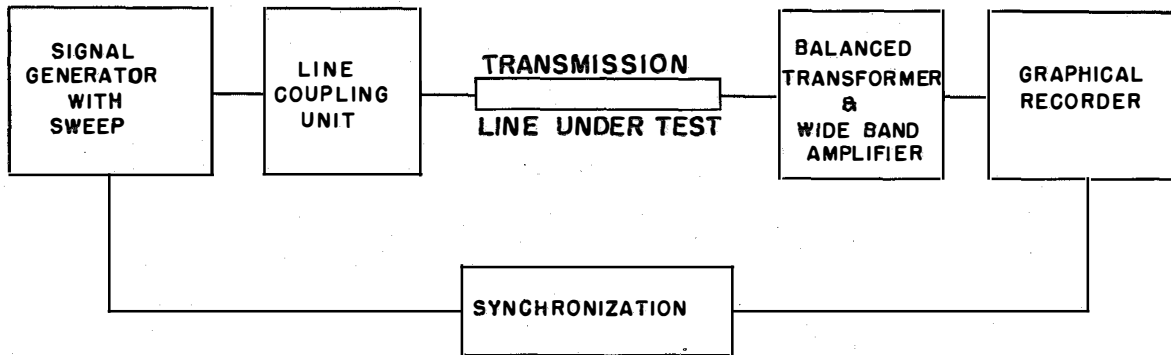

Fig. 4—Wide band high frequency balance test recording—block diagram.

reflected voltages are spaced quite at random, resulting in an unbalanced input impedance. Here again, manufacturing technique is of prime importance in minimizing these effects.

Advantages and Disadvantages of Balanced Cables

A number of advantages result from the use of balanced cables because of the inherent construction of associated equipment. For instance, many loads placed at the end of transmission lines are basically balanced, a good example being a dipole radiator. When such a dipole is required for operation over a very wide band of frequencies, it must be fed by some balanced system; otherwise, a loss of efficiency will be incurred or coupling from voltages induced on the masts supporting the dipole may result. A loop antenna is also inherently balanced and balanced cables are often used to feed such antennas. Many receiver inputs are constructed for balanced input since the latter is very effective in rejection of extraneous pickup; rejection of extraneous pickup, in fact, is one of the main functions of balanced cables. Further, it is often found that when the shields for coaxial transmission lines cannot be kept perfectly continuous and constant in size, a balanced transmission line is an excellent solution. A break in the shield would not interfere with the operation of a balanced cable, whereas a break in the shield of a coaxial line would seriously hamper the results.¹

Any pickup along the balanced cable is intro-

duced equally into each leg of the balanced transmission line, and can be rejected by a balanced transformer at the input to the receiver. It is difficult to reject extraneous pickup from a coaxial transmission line since, once it is introduced, it must be differentiated from the true current with which it has combined. On frequencies below 30 megacycles in many applications, it is almost compulsory to use balanced cables to avoid extraneous pickup. In some cases it is also desirable to obtain a 180° phase reversal independent of frequency. This can be accomplished with a balanced cable by transposing the transmission line. In a coaxial type of transmission line, it is rather difficult to obtain such a reversal other than through a 180° extra length of line.

In some instances balance-to-coaxial conversion transformers may be used,² and either a balanced or coaxial cable may be employed as desired.

One of the disadvantages of a balanced cable is difficulty in installation. As already stated, it must always be bent at right angles to the plane of the two wires.

The twisted balanced cable, as illustrated in Fig. 1C, obviates some of the difficulty encountered in installation. Even when using a twisted cable, however, care should be used so that the bend occurs at a point along the twist wherein the two conductors are at right angles to the plane of the bend.

Fittings and connectors required for balanced cables are more complicated and difficult to

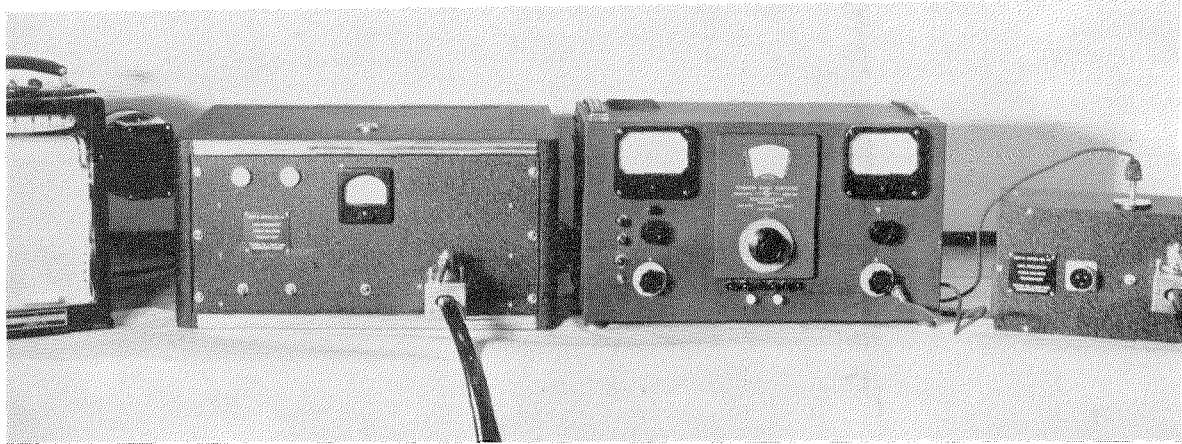

Fig. 5—Wide band high frequency balance test recording equipment.

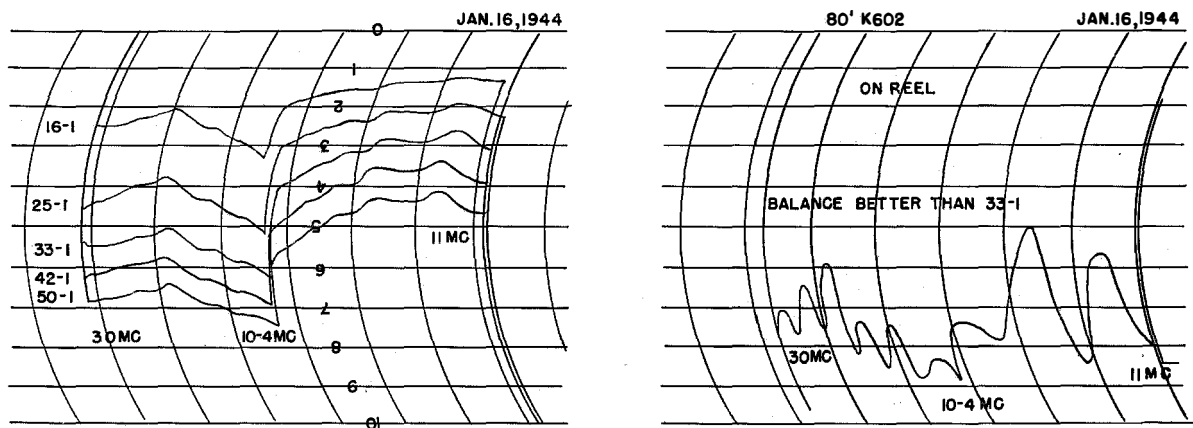

Fig. 6—Graphs obtained with wide band high frequency balance test recording equipment.

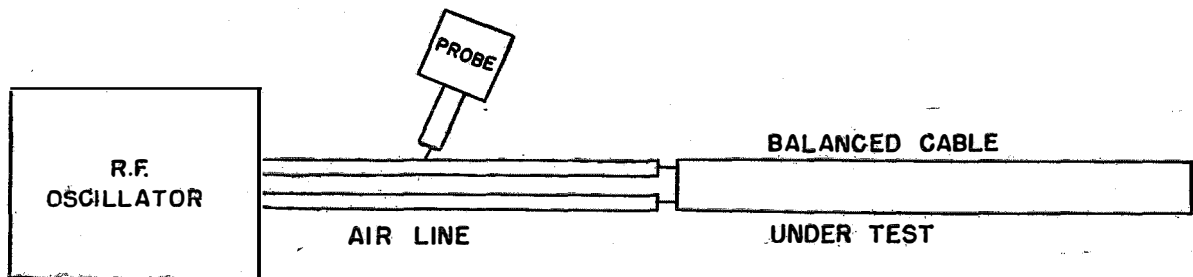

Fig. 7—Electrical length method of testing balance.

handle than those for coaxial lines. Combined with the fact that balanced cables are necessarily more expensive, the resulting installation is more costly.

Balanced Measurements of Dual Coaxial Cables

The basic method of measuring balanced cables requires the insertion of a highly balanced voltage into the cable input and measurement of the unbalance at the output. A simple way of obtaining the same result is to impress two equal voltages on both sides of the cable input and measure the difference between the two voltages at the output. When these two equal voltages are impressed on the input, and the differences measured at the output, the results are exactly the same as would be obtained if the basic method of measurement were used.

It must be realized, nevertheless, that the amount of voltage obtained at the output is a function of frequency. When the balanced cable is to be used over a very wide band of frequencies, it is often necessary to run the balance tests over the entire band. One method is to use a signal generator with a sweep motor and a recorder which graphically records the unbalance ratios, i.e., the ratios of balance-to-unbalance voltages existing at the output of the cable. Figs. 4 and 5 illustrate a testing system (developed by A. G. Richardson, J. Koleda and C. Bednash of Federal Telephone & Radio Laboratories) consisting of a signal generator with a sweep attachment, a line coupling unit which couples the signal generator into the transmission line under test, a terminating device consisting of a highly balanced transformer, and a wide band amplifier which feeds into a graphical recorder. The graphical recorder synchronized with the sweep on the signal generator gives immediate results in the form of a graph of unbalance voltage

versus frequency. This graph may be attached to the reel of the cable under test, thus furnishing a record of its characteristics for field use.

Fig. 6 shows a calibration curve graphically recorded over the frequency range of 4 to 30 megacycles. For this recording, special resistor type unbalance generators were used in order to obtain accurate unbalance calibration curves. The test curve in Fig. 6 indicates a balance better than 33 to 1, which was very satisfactory for the use to which the cable was to be placed. For special uses, cables with much higher balance ratios are available.

Another method of testing balance at very high frequencies (developed by R. Hampshire of F.T.R.), especially useful for a coaxial type balanced cable, is shown in Fig. 7. It employs a radio frequency oscillator with a highly balanced output arranged for feeding into a balanced air line which is connected to the balanced cable under test. The far end of the balanced cable is shorted. A probe detector is used to determine where the nulls of the air line are located. If both nulls on the balanced line occur at the same point, the electrical lengths of the balanced cable are equal. If the nulls do not coincide, their separation corresponds to the difference in electrical lengths of both sides of the balanced cable under test.

Both of these methods have given excellent results in production testing, and there are now available highly balanced cables which maintain necessary balance ratios. Obviously, service applications impose different requirements, including balance ratios, and the type of cable must be selected with the specific requirements in mind.

References

1. N. Marchand: "Complex Transmission Line Network Analysis," *Electrical Communication*, Vol. 22, No. 2, 1944.
2. N. Marchand: "Transmission Line Conversion Transformers," *Electronics*, December, 1944.

Special Transmission Problems In Solid Dielectric High Frequency Cable

By A. G. KANDOIAN

Federal Telephone and Radio Laboratories, New York, N. Y.

I. Introduction

THE general theory of transmission lines, all of which is of course applicable to solid dielectric, high frequency cables, has been adequately discussed by many investigators in textbooks and technical publications.

In dealing with many specific high frequency transmission line problems, however, the mathematics become unnecessarily laborious so that many useful engineering relationships are derived through simplifying assumptions. These assumptions are that the (1) velocity of propagation is equal to that of light, (2) attenuation along the line is negligible, (3) surge impedance is pure resistance, etc. These all hold for normal, air dielectric transmission lines, whether of coaxial, balanced shielded, or balanced open-type where the spacing between conductors is kept small compared to the wavelength.

For solid dielectric cables, such assumptions must be reviewed as they do not necessarily apply and may cause misconceptions and serious errors. For example, the first assumption is no longer valid since the velocity of propagation is now reduced from that of the velocity of light by the factor $\sqrt{\epsilon}$, where ϵ is the dielectric constant of the solid dielectric of the cable. The second assumption also becomes very doubtful inasmuch as considerable attenuation may exist depending primarily on the size of the cable, the frequency utilized, and the quality of the dielectric. The third assumption is still quite good for most engineering applications.

In the following discussion, the attenuation problem will be primarily considered. Several special cases, important in communication practice, will be analyzed to show how the appreciable attenuation of the solid dielectric cable affects the results. The derivations are given in Appendix I.

II. Standing Wave Ratio at Any Point on the Line

In most air dielectric line applications where a certain mismatch occurs at the load end of the transmission line, it may be assumed that the same mismatch exists at the generator end. This assumption will be quite erroneous if appreciable attenuation is present, as is usually the case with solid dielectric transmission lines.

This problem is illustrated in Figs. 1a, 1b, and 1c, representing a cable with attenuation of 6 decibels. It is evident that the standing wave ratio $\rho = \frac{V_{\max}}{V_{\min}}$ is not the same over the length of the cable.

Analytically, the results may be expressed in a group of equations given below in which

l = length of the transmission line

x = distance to any point on the transmission line measured from the transmitter end

α_0 = normal attenuation of the transmission line in nepers per unit length

a_0 = normal attenuation of the transmission line in decibels per unit length

A_0 = total normal attenuation of the transmission line in decibels

A = total complete attenuation of the line in decibels

Δ = equivalent real reflection coefficient

ρ = standing wave ratio = $\frac{V_{\max}}{V_{\min}} = \frac{I_{\max}}{I_{\min}}$

The subscript L denotes the load end of the line; the subscript T , the transmitter end of the line. For example, ρ_L denotes the standing wave ratio at the load whereas ρ_T denotes the ratio at the transmitter.

From the above definitions, the following well-known relationships follow immediately:

$$\alpha_0 = 0.115a_0, \tag{1}$$

$$a_0 l = A_0, \tag{2}$$

$$\rho = \frac{1 + \Delta}{1 - \Delta}, \tag{3}$$

$$\Delta = \frac{\rho - 1}{\rho + 1}. \tag{4}$$

The standing wave ratio at the transmitter, as a function of the line attenuation and the standing wave ratio at the load, is given by

$$\rho_T = \frac{1 + \Delta_L \epsilon^{-2\alpha_0 l}}{1 - \Delta_L \epsilon^{-2\alpha_0 l}}. \tag{5}$$

The more general relationship is

$$\rho_x = \frac{1 + \Delta_L \epsilon^{-2\alpha_0(l-x)}}{1 - \Delta_L \epsilon^{-2\alpha_0(l-x)}} \tag{6}$$

which gives the standing wave ratio at any point along the line.

An interesting special case is the one where no reflection takes place at the load end of the transmission line, i.e., the line is matched.

Then $\Delta_L = 0$; hence

$$\rho_T = \rho_x = 1 \tag{7}$$

and no standing waves exist anywhere along the line.

Another interesting case is where complete reflection takes place at the load, i.e., the line is short circuited, open or terminated in pure reactance. Now $\Delta_L = 1$, giving as a result

$$\rho_x = \frac{1 + \epsilon^{-2\alpha_0(l-x)}}{1 - \epsilon^{-2\alpha_0(l-x)}} = \coth [\alpha_0(l-x)], \tag{8}$$

$$\rho_T = \frac{1 + \epsilon^{-2\alpha_0 l}}{1 - \epsilon^{-2\alpha_0 l}} = \coth (\alpha_0 l). \tag{9}$$

The significance and usefulness of the above relationships will be apparent to engineers familiar with transmission line measurements. For example, it is evident from Fig. 1 and equation (5) that the standing wave ratio at the transmitter is substantially below that at the load end of the line. Hence, if proper termination of the transmitter is the main problem, as it is

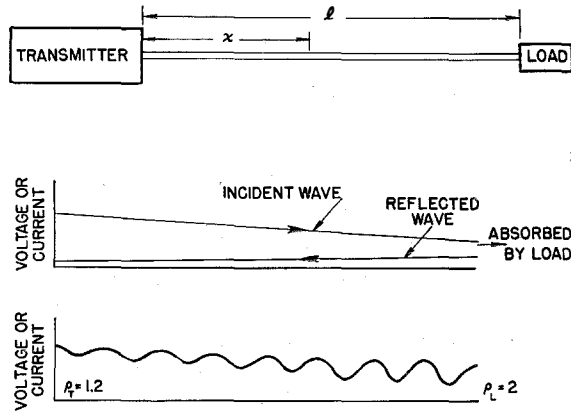

Fig. 1—*a*, Layout; *b*, incident wave and reflected wave; *c*, resulting standing waves.

in many practical applications, it may not be worthwhile to devote much effort to “flattening the load” because the line itself does a great deal of “flattening” before the reflected wave reaches the transmitter.

By transformation of equation (9) we obtain

$$A_0 = 8.7 \alpha_0 l = 10 \log_{10} \frac{\rho_T + 1}{\rho_T - 1}. \tag{10}$$

Thus the total normal attenuation of any transmission line may be obtained by simply measuring the input standing wave ratio when the far end has complete reflection, i.e., when it is terminated in open circuit, short circuit, or a completely reactive load. In Fig. 2 the practically useful region of equation (10) is plotted.

In connection with the standing wave ratio on the line, the problem of random irregularities in solid dielectric cables merits brief consideration. Irregularities in well designed cables are not great and may be neglected for most engineering applications. However, some slight irregularity always exists and thus provides a residual mismatch along the transmission line, which may be compensated for at any given frequency but never completely removed for a wide band of frequencies. The connectors used with these cables also contribute to the irregularities. It follows, therefore, that it is seldom worthwhile to attempt matching a load to the solid dielectric transmission line with extreme precision, say to a ratio of better than $\rho = 1.02$.

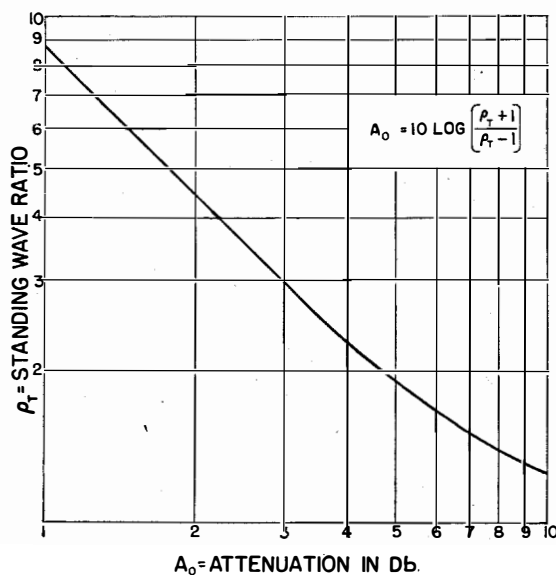

Fig. 2.

III. Total Attenuation and Efficiency Considerations

It is well known that, for best efficiency of transmission, the load as well as the transmitter output circuit must be matched to the surge impedance of the transmission line. Transmitter "coupling" or matching does not fall within the scope of the present paper so that the discussion will be limited to problems involving the matching at the load end of the line.

Since best efficiency requires perfect matching at the load, a pertinent question is how much is lost if perfect matching is not achieved for practical reasons.

Equation (11) gives the expression for the total loss A (db) in the transmission line as a function of the total normal attenuation A_0 (db) and reflection coefficient Δ , all defined in section II.

$$A = A_0 + 10 \log_{10} \left[\frac{1 - \Delta_L^2 \epsilon^{-0.46A_0}}{1 - \Delta_L^2} \right]. \quad (11)$$

The total normal attenuation A_0 is the line attenuation when no mismatch is present at the load, i.e., the lowest possible attenuation of the given transmission line. A_0 may be obtained readily from data furnished by the cable manufacturer in decibels per foot or per 100 feet.

To indicate the significance of equation (11) more clearly, a family of curves has been plotted in Fig. 3. These curves show the additional losses introduced into the transmission line

system due to load mismatch. It is evident, if the normal attenuation A_0 is negligible, that the additional loss in the line due to any amount of mismatch is also negligible. On the other hand, when both the normal attenuation and the load mismatch are large, quite an appreciable additional loss exists due to this mismatch. Nevertheless, for most applications where the load mismatch is less than two, a condition relatively easy to achieve, the additional loss due to mismatch is small—less than approximately one-half decibel, regardless of the normal attenuation of the cable.

From strictly transmission line efficiency considerations—loss of signal power in the transmission line—reduction of mismatch to less than $\rho=1.5$ or perhaps $\rho=2$ is hardly justified. However, other valid reasons for obtaining an extremely good match at the load may be controlling.

IV. Power Considerations in Solid Dielectric Cables

Solid dielectric cables possess an obvious advantage over air dielectric transmission lines of equivalent size from the viewpoint of voltage breakdown. Greatly improved breakdown voltage values are of course due to the character of the dielectric material utilized.

A disadvantage of solid dielectric cables results from the fact that the dielectric is an effective heat insulant so that power dissipated within the line in the form of heat cannot escape readily. The resulting temperature rise within the cable may cause rapid softening or deterioration of the insulation material.

It is accordingly useful to know the power dissipation per unit length of line at any point on the transmission line. The relationship involved is a function of the available transmitter power and the attenuation per unit length of the given transmission line.

If ΔW_x = power dissipation per length of line Δx at any point on this line in watts
 W_x = power being transmitted at any point on the line in watts
 a_0 = attenuation per unit length of line in decibels.

Then

$$\Delta W_x = 0.23 W_x a_0 \Delta x. \quad (12)$$

As an example of the usefulness of this relationship, assume that a one-kilowatt transmitter delivers power to its load through a short length of transmission line of, say, 3 db attenuation per 100 feet.

Two questions may be raised: (1) What would be the maximum power dissipation per foot along the transmission line?; (2) Is the transmission line (solid dielectric cable) capable of continuously dissipating this power?

The first question is answered readily by equation (11). The dissipation is maximum adjacent to the transmitter where the power is maximum. Hence

$$\Delta W_T = 0.23(1000)3 \frac{1}{100} = 6.9 \text{ watts per foot.}$$

The second question depends on the material and construction of the transmission line. Manufacturers of solid dielectric cables probably are in a position to advise how much maximum dissipation per foot of line is permissible for lines of various types.

APPENDIX 1. DERIVATIONS

A. Standing Wave Ratio at Any Point on the Line

Let \overrightarrow{M} represent the forward wave and \overleftarrow{M} the backward wave (either current or voltage) on the transmission line. With an attenuation factor of α_0 and assuming a wave of unit amplitude at the origin,

$$\overrightarrow{M} = \epsilon^{-\alpha_0 x} \tag{13}$$

This wave reaches the load where reflection takes place. The reflection coefficient in general is complex but, for the standing wave ratio on the line, the complex reflection coefficient may be replaced by the equivalent real reflection coefficient Δ_L . Then

$$\overleftarrow{M} = \Delta_L \epsilon^{-\alpha_0(2l-x)} \tag{14}$$

These waves, traveling in opposite directions, give rise to standing waves whose maximum and minimum values can be obtained from the sum and difference of the traveling waves.

$$M_{\max} = \epsilon^{-\alpha_0 x} [1 + \Delta_L \epsilon^{-2\alpha_0(l-x)}], \tag{15}$$

$$M_{\min} = \epsilon^{-\alpha_0 x} [1 - \Delta_L \epsilon^{-2\alpha_0(l-x)}], \tag{16}$$

$$\rho_x = \frac{M_{\max}}{M_{\min}} = \frac{1 + \Delta_L \epsilon^{-2\alpha_0 l}}{1 - \Delta_L \epsilon^{-2\alpha_0 l}} \tag{17}$$

Equation (17) is the same as equation (6) given in section II. All other equations in that section may be derived by simple substitution or transformation.

B. Total Attenuation

Power directed towards the load at any point W_x is equal to the power in the forward wave less the power in the backward wave. Assume, for example, unit voltage wave, and let Z_0 be the surge impedance.

$$W_x = \frac{(\epsilon^{-\alpha_0 x})^2}{Z_0} - \frac{(\Delta_L \epsilon^{-\alpha_0(2l-x)})^2}{Z_0} \tag{18}$$

At the transmitter, $x=0$:

$$W_T = \frac{1}{Z_0} [1 - \Delta_L^2 \epsilon^{-4\alpha_0 l}] \tag{19}$$

At the load, $x=l$:

$$W_L = \frac{1}{Z_0} [\epsilon^{-2\alpha_0 l} - \Delta_L^2 \epsilon^{-2\alpha_0 l}] \tag{20}$$

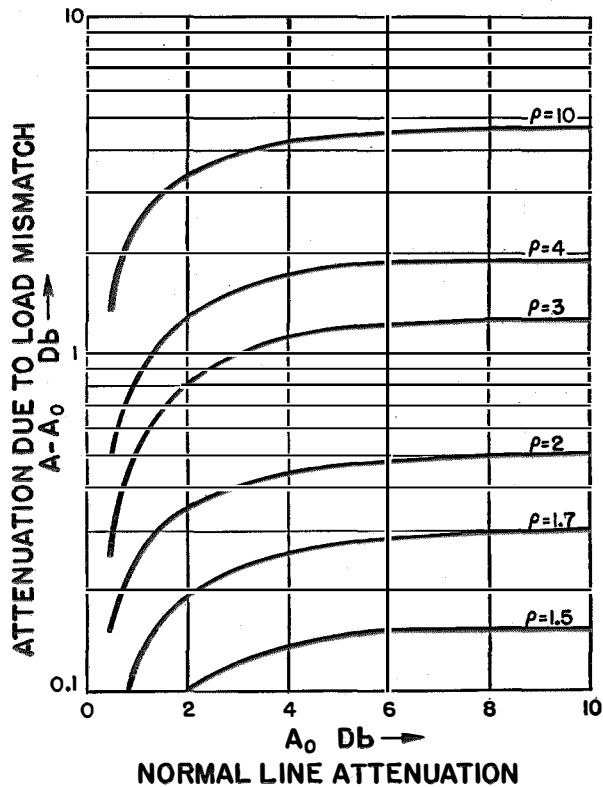

Fig. 3.

The total attenuation is then:

$$A = 10 \log_{10} \frac{W_T}{W_L} = 10 \log_{10} \left[\epsilon^{2\alpha_0 l} \right] \left[\frac{1 - \Delta_L^2 \epsilon^{-4\alpha_0 l}}{1 - \Delta_L^2} \right]. \quad (21)$$

Let A_0 be the normal attenuation, when reflection at the load is zero ($\Delta_L = 0$):

$$A_0 = 10 \log_{10} \epsilon^{2\alpha_0 l} = 8.7(\alpha_0 l). \quad (22)$$

Therefore

$$A = A_0 + 10 \log_{10} \left[\frac{1 - \Delta_L^2 \epsilon^{-0.46A_0}}{1 - \Delta_L^2} \right]. \quad (23)$$

C. Power Dissipation

From equation (18), the power in a matched line is:

$$W_x = \frac{1}{Z_0} [\epsilon^{-\alpha_0 x}]^2. \quad (24)$$

Differentiating

$$\Delta W_x = -W_x [2\alpha_0 \Delta x]. \quad (25)$$

The negative sign means that the power decreases with distance x and, hence, it is not significant from the power dissipation standpoint. Transforming from α_0 in nepers to a_0 in decibels:

$$\Delta W_x = 0.23 W_x a_0 \Delta x. \quad (26)$$

Errata, Vol. 22, No. 2, 1944

PULSE TIME MODULATION, Page 92

The patent references in the footnotes to this article should be corrected, respectively, as follows:

1. A. H. Reeves, French patent 833,929, délivré August 1, 1938.
2. A. H. Reeves, French patent of addition 49,159, délivré August 22, 1938.
3. E. M. Deloraine and A. H. Reeves, British patent 509,820, accepted July 19, 1939.

(In the published article the first patent contained a typographical error. The last two footnotes referred to application numbers rather than to patent numbers.)

United Air Lines' Reperforator Switching System

By R. E. HANFORD, F.E.

Western Union Telegraph Co., New York, N. Y.

EFFICIENCY in the operation of any commercial transportation system is determined in large measure by the speed and accuracy of its communication facilities.

The development and expansion of railroads in the U. S. A. have been at a very rapid rate, so rapid, in fact, that railroad transportation is now one of the largest industries. This phenomenal growth has been possible because direct communications between stations have provided instantaneous remote control of train movements, train reports, car loadings, freight and express shipments, passenger reservations, diversions, disposition of "empties," schedules for extra trains, emergency measures and reroutings in case of accidents, breakdowns, washouts, etc.

The modern railroad has many types of electrical communication facilities at its disposal and makes extensive use of Morse circuits, teleprinter circuits, multiplex circuits, radio, telephone, facsimile,¹ and reperforator switching systems.

Commercial air transportation is a development so recent that its organization is well within the memory of most of us. Its growth in this short period, however, has been far more rapid than that of the railroad industry for any period of equal length and, in spite of its youth, commercial aviation is now an important factor in the Nation's industrial expansion.

For the efficient and safe operation of commercial passenger, mail and express planes, and freight transport planes, fast and accurate communication facilities are a vital necessity.

United Air Lines, one of the largest and most aggressive commercial aviation corporations in the U. S. A., recognized the importance of adequate communication facilities early in its development and made a thorough investigation of available equipment and operating methods. In keeping with the progressive spirit of the organization, United Air Lines took advantage of

some of the most recent developments in communication systems and adopted the Western Union Telegraph Company's reperforator switching method of operating a network of teleprinter circuits. The network is used for communications between airports and city business offices on the United Air Lines system and is supplemented by two-way radio communication facilities between airports and planes in flight.

The route of United Air Lines extends from the Atlantic to the Pacific and, on the west coast, from Canada to southern California, a total of some 6,000 miles of airways. Its "Mainliners," passenger-mail-express planes, fly at 200 miles per hour and there are periods during the day when as many as 32 of them are in the air at one time.

Fast and efficient operation of this vast airlines system is possible because it is supplemented by the 9,000-mile communication network shown diagrammatically by Fig. 1. Over this network, in service 24 hours a day, teleprinter and switching operators rush to their destinations somewhat over twenty million words per month.

The telegraph traffic handled over this network is very similar in content to that handled over railroad communication systems: plane movements and reports, plane loadings, shipment diversions, passenger reservations, passenger seating diagrams, schedules for extra planes, emergency measures, and reroutings in case of breakdowns or other causes of delayed schedules. In addition, and of prime importance to airlines operation, weather reports are transmitted frequently and in detail with the result that the operations office at every major airport on the United Air Lines system knows the weather conditions at all sections of the country every hour of the day.

Normally, weather reports are handed to plane pilots prior to the take-off of each flight but sudden and unexpected weather changes, which occur during a flight, are often transmitted to the airport nearest the position of the plane in flight and relayed by radio to the plane pilot.

¹"Train Orders by Facsimile Telegraphy" by J. H. Hackenberg and G. H. Ridings, *Electrical Communication*, Vol. 21, No. 2, 1943, pp. 95-102.

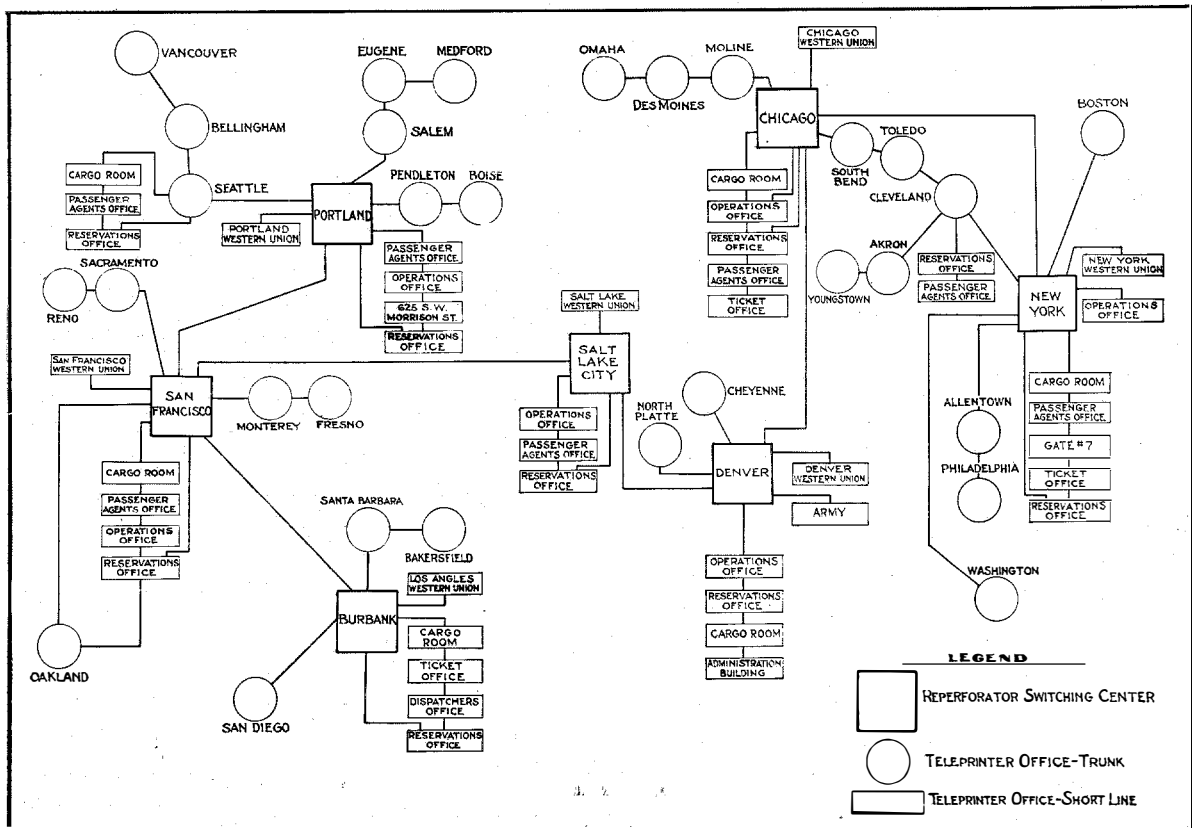

Fig. 1—United Air Lines' 9000-mile communication network.

All planes in flight report their positions periodically by radio to strategically-located ground stations on the wire network and these reports are relayed to airports of destination. In this way, records of each plane's progress in flight are maintained and arrival times are readily calculated. To expedite the transfer of messages from the wire network to radio channels and vice versa, United Air Lines has located its radio and teleprinter operators in the same room and under common supervision at the communication centers.

As shown by Fig. 1, the United Air Lines leased wire network provides telegraph communication facilities between 37 cities, 36 in the U. S. A. and one in Canada. In some of the larger cities there are as many as seven distinct United Air Lines offices which have telegraph connection to the network. All of the facilities shown on this map, except the one lead which extends into Canada, are leased from the Western Union Telegraph Company.

The layout of telegraph circuits on this map does not provide direct telegraph channels from each office on the network to every other office. Experience has demonstrated that the most efficient handling of point-to-point telegraph traffic on a large network can be obtained by providing major telegraph centers with interconnecting trunks and by relaying at these major telegraph centers all traffic to and from the minor or tributary offices. The arrangement of circuits forming the United Air Lines network is in accordance with these principles.

The relaying of telegraph traffic on the United Air Lines network is performed at seven major telegraph centers. These are located at New York, Chicago, Denver, Salt Lake City, San Francisco, Burbank, and Portland.

The time consumed in the transmission of a telegraph message from a tributary office to a telegraph center or from one telegraph center to another is only a matter of seconds. The overall transmission efficiency of a network like that of

United Air Lines, therefore, is determined largely by the speed and accuracy of the relaying facilities at the major telegraph centers.

The relaying facilities employed by the United Air Lines at the major telegraph centers provide exceptionally expeditious handling of point-to-point telegraph traffic. The method is known as Reperforator Switching. The relaying offices which employ this method are called Reperforator Switching Centers, or simply, Switching Centers. Each message on the network is transmitted manually only once, at the point of origin. All retransmission is automatic, and requires only a switching operation.

At a switching center, an incoming message is recorded on a paper tape by a printer perforator. The tape passes through a tape transmitter which automatically retransmits the message when the switching operator makes the connection to the selected sending circuit. In a

matter of seconds, the message is in and out of the switching center.

The printer perforator performs the dual function of printing the message on the upper margin of a paper tape, $\frac{7}{8}$ inch wide, and

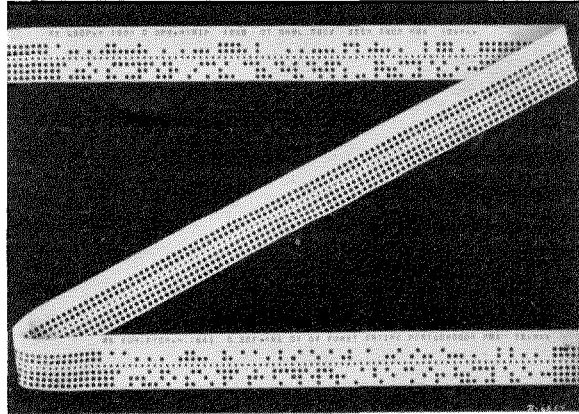

Fig. 2—Specimen of printed and perforated tape.

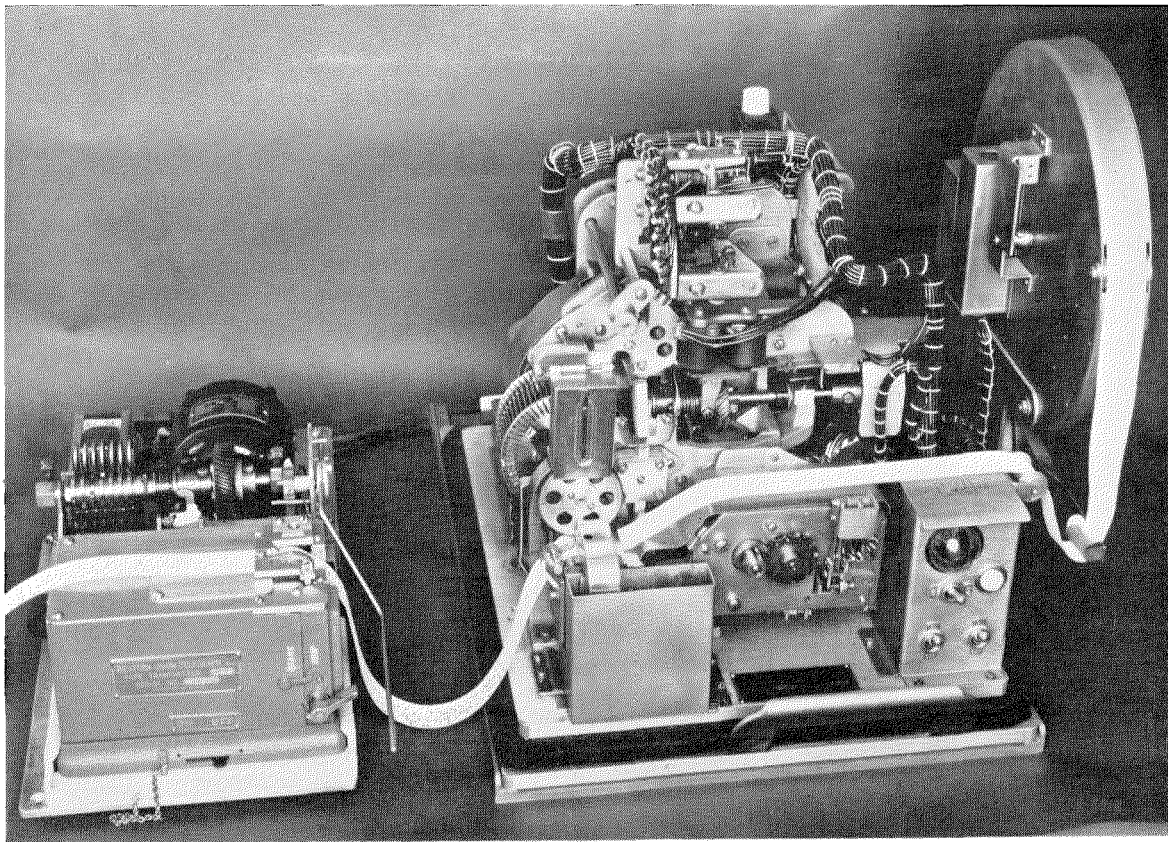

Fig. 3—Printer perforator (right), tape transmitter, and perforated tape.

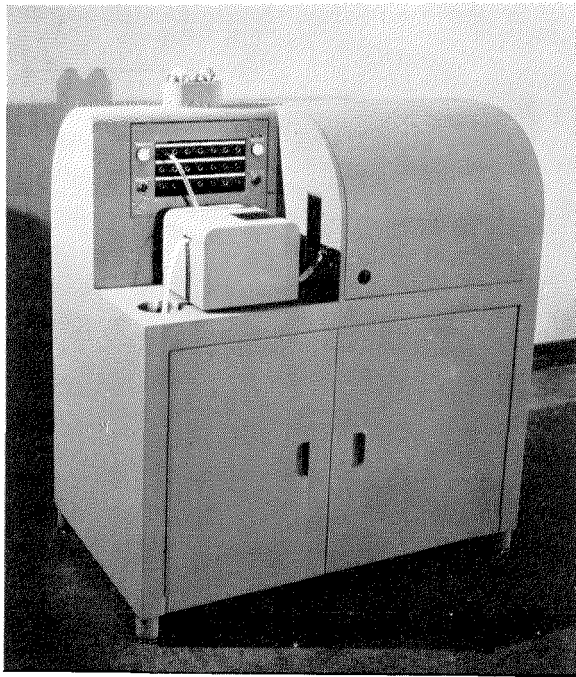

Fig. 4—Console enclosing printer perforator, tape transmitter, and auxiliary equipment.

perforating the message in telegraph (Baudot) code directly underneath. A sample of this tape is shown by Fig. 2. The printed message simplifies the procedure of the switching operator and expedites the transfer of the message through the switching center. The perforations in the tape provide the means by which the tape transmitter retransmits the message to the outgoing circuit. The large holes in the tape constitute the message

characters. The small center holes are feed holes by means of which the tape is stepped through the tape transmitter. The messages appearing on the tape shown by Fig. 2 are reproductions of traffic actually handled on the United Air Lines network. As indicated by the printed text, many abbreviations are used.

Fig. 3 shows a printer perforator, a tape transmitter, and the printed and perforated tape as it moves from the former to the latter. Fig. 4 shows the console which is used to enclose the printer perforator, tape transmitter, and auxiliary equipment.

Tape Feed Out

Each message on the system is terminated with two Carriage Returns and one Letter Shift. Switching relays associated with each printer perforator record the reception of Carriage Return and Letter Shift characters. When the end of a message is indicated by the consecutive reception of Carriage Return and Letter Shift, the switching relays initiate a circuit which causes the printer perforator automatically to feed out tape if tight tape occurs between the printer perforator and the tape transmitter. The characters perforated in the tape during the feed out are the same as the last character received by the printer perforator—in this case, Letter Shift—and the length of the feed out is sufficient to permit the last character of the message to pass through the tape transmitter. If the message is immediately followed by another message, no

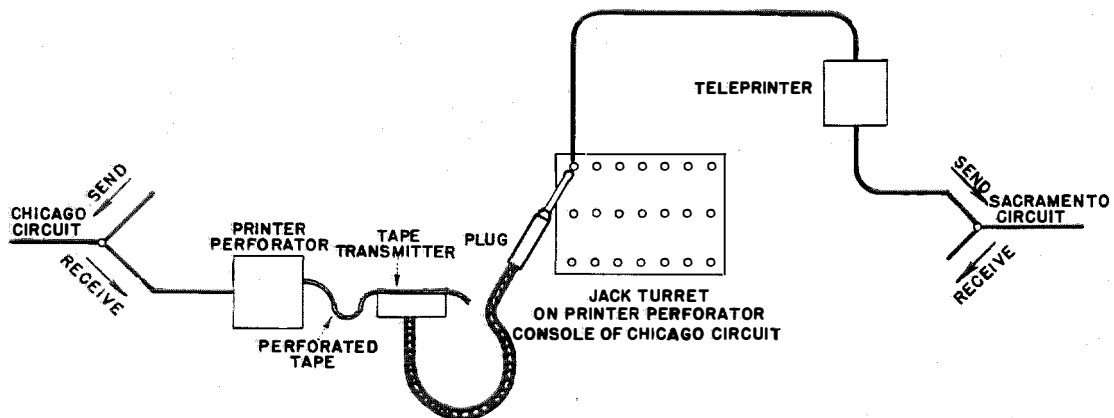

Fig. 5—Reperfector switching center, San Francisco.

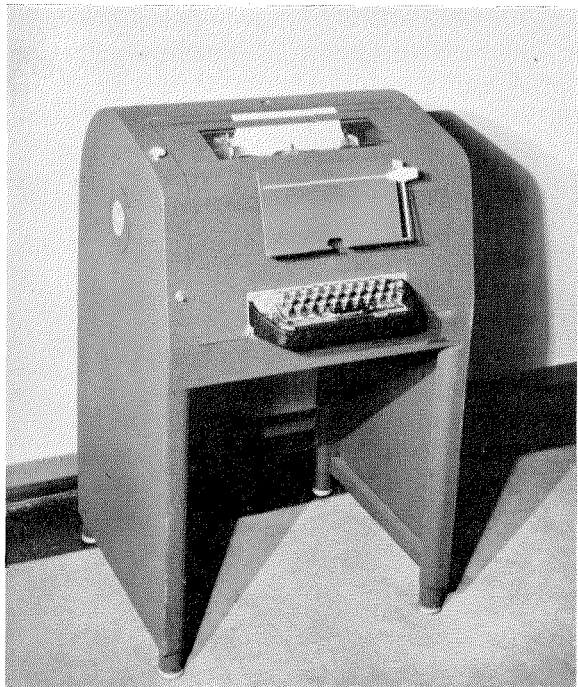

Fig. 6—Teleprinter and its console.

feed out occurs. If the start of a following message is received during a feed out, the feed out immediately stops and no characters are mutilated. Only one feed out occurs after a message even though the tape may become tight a second time.

Tape Transmitter Control Circuits

During the idle condition of the circuit, the tape between the printer perforator and the tape transmitter contains only the Letter Shifts which resulted from the last feed out. When the start of the next message is received by the printer perforator, the tape between the printer perforator and the tape transmitter becomes slack and, under this condition, control relays associated with the tape transmitter cause the tape transmitter to step the tape as long as the characters appearing over the code pins of the tape transmitter are Letter Shifts. As soon as any character, other than Letter Shift, arrives over the code pins, the stepping of the tape stops and the "Message Waiting" lamp (left lamp of the two lamps shown on Fig. 4) lights notifying the switching operator that a message has arrived at this position and is ready for retransmission.

Associated with each tape transmitter are a three-conductor plug and a turret (jack panel) as shown on the upper left portion of the printer perforator console, Fig. 4. Each jack in the turret is connected in the sending side of one of the circuits terminated at the switching center. When the switching operator arrives at the printer perforator console in response to the lighting of a message waiting lamp, she reads the destination which appears on the tape at the beginning of the waiting message, then inserts the plug in the jack which is connected to the indicated circuit.

If no other transmitter is sending to the circuit, the waiting message starts immediately and the message waiting lamp is extinguished. If the circuit is busy, however, the waiting message is held until the circuit becomes clear, at which time the waiting message starts automatically without further attention by the switching operator.

Once the message starts, it continues until completed. When the second Carriage Return of the message termination—Two Carriage Returns and One Letter Shift—appears over the code pins of the tape transmitter, character-reading relays function to stop the tape transmitter and disconnect it from the sending side of the line circuit so that the line circuit is cleared for any

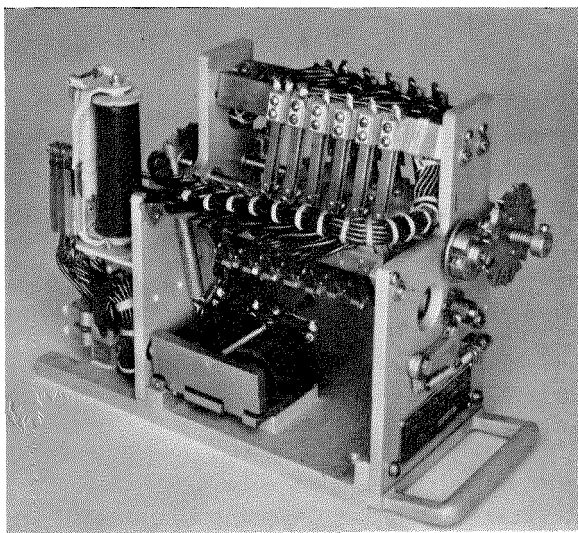

Fig. 7—Automatic message numbering machine.

other messages which may be waiting for retransmission at other printer perforator consoles. As the tape transmitter disconnects, the "Disconnect" lamp (right lamp above turret) is lighted informing the switching operator that the retransmission of the message has been completed. The plug may be removed at the convenience of the switching operator as the line circuit was cleared for other traffic when the tape transmitter disconnected.

Sending Teleprinters

An example of the course of a message through a switching center is illustrated diagrammatically by Fig. 5. The message, in this case, is from Chicago and is received at the reperforator switching center in San Francisco. Its destination is Sacramento. This example is typical of the transit of any message through any one of the seven reperforator switching centers.

As indicated on Fig. 5, the sending side of each line circuit includes a teleprinter. The teleprinter is enclosed in a console as shown on Fig. 6. The teleprinter serves two purposes. It provides a printed record of all messages retransmitted to the line circuit in which it is connected

and its keyboard is used to transmit messages which originate locally. The messages sent on the keyboard also are recorded by the printer and are filed chronologically with the retransmitted messages to serve as the office record of all traffic sent to this circuit. To prevent simultaneous transmission to a sending circuit from both the keyboard and a tape transmitter, each teleprinter console is equipped with a switch which connects the sending circuit either to the keyboard or to the associated turret jacks. If a tape transmitter is "plugged up" to the sending circuit while the switch is in the keyboard position, the tape transmitter does not start. A lamp, however, on the teleprinter console lights and informs the keyboard operator that a message is waiting for retransmission.

If an operator tries to send on the keyboard while the switch is in the tape transmitter position, nothing happens as the keyboard is electrically shorted by contacts on the switch. If the switch is thrown from tape transmitter to keyboard while a tape transmitter message is in transit, that message will continue and the electrical short will be maintained across the keyboard contacts until the message is completed.

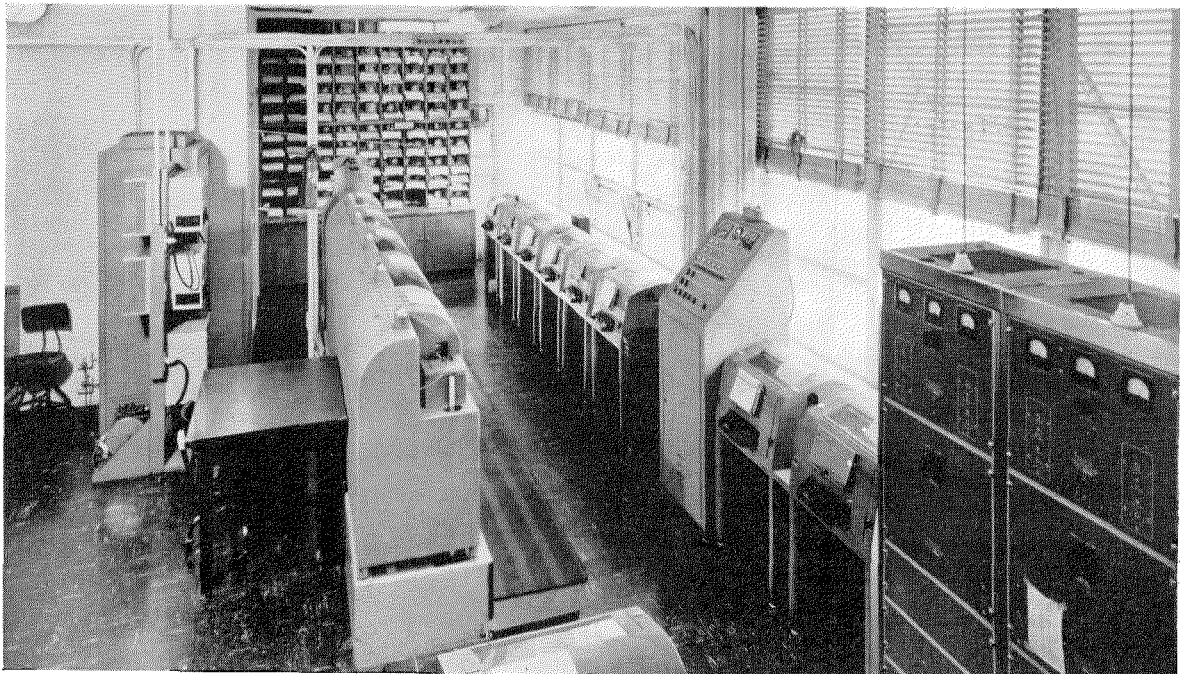

Photo Courtesy United Air Lines

Fig. 8—Portland, Oregon, switching center showing reperforator switching section.

Multiple Turrets

As indicated by Fig. 4, an individual turret is associated with each tape transmitter. Jack No. 1 in each turret is multiplied to Jack No. 1 in every other turret and this multiple is connected to a particular sending circuit. In like manner, all Jacks No. 2 are multiplied and connected to another sending circuit, etc.

If two messages destined to Sacramento are received at the same time on two of the printer perforators in the San Francisco office, it is possible that two switching operators will plug up to Sacramento jacks simultaneously. The switching relays associated with the tape transmitter circuits and sending circuits provide for this contingency and are arranged to connect only one tape transmitter at any one time. The second message and any others which may be plugged up to Sacramento at the same time will follow, another starting as soon as the one in transit is completed.

Local Receiving Teleprinters

Each reperforator switching center on the United Air Lines network has several local receiving teleprinters which, like the sending teleprinters, are enclosed in consoles as shown by Fig. 6. Each local receiving teleprinter is connected in a circuit which is multiplied to a jack in each of the turrets. Messages received on a printer perforator and destined for local delivery, and not for retransmission to another circuit, are plugged up to one of the local receiving teleprinters and the teleprinter furnishes the delivery copy.

Local Transmission

Messages originating locally may be transmitted directly to the desired sending circuit by operation of the teleprinter keyboard associated with that sending circuit or they may be punched up in the form of perforated tape and then plugged up to the sending circuit. The latter procedure is often employed when the sending circuit is busy or when the text of the message to be sent is of a complex and/or important nature requiring careful and deliberate punching

by the sending operator. A printer perforator, and the keyboard of one of the local receiving teleprinters, are permanently assigned for this purpose. This use of the keyboard does not interfere with the local receiving function of the teleprinter.

Automatic Message Numbering Machines

On all circuits of the United Air Lines network, messages are numbered consecutively throughout every 24-hour period, the number series starting with "One" at midnight. At some reperforator switching centers, the sending circuits are equipped with automatic message numbering machines. The automatic message numbering machine is shown on Fig. 7. The characters to be transmitted are set up on a series of contacts mechanically operated by studs on a rotating cylinder. The cylinder is stepped and the characters are transmitted by a distributor transmitter electrically connected to the automatic message numbering machine.

When a message is plugged up to a sending circuit, the switching relays associated with this circuit connect it first to the automatic message numbering machine and start operation of the machine. A number is transmitted and, when it has been completed, the switching relays transfer the sending circuit to the tape transmitter which was plugged up and the message follows immediately. The number, which is transmitted before the message, appears on the printed copy of the message at the distant terminal and also on the printed copy recorded by the sending circuit teleprinter at the reperforator switching center. This provides a definite series of consecutive numbers at both terminals and facilitates the location of sent messages when comparisons are necessary.

The automatic message numbering machine may be operated by a push button located on the console of the sending circuit teleprinter when a message is to be sent on the keyboard of this teleprinter. In this way the number series is maintained and all messages sent to the particular circuit carry their respective numbers in the series.

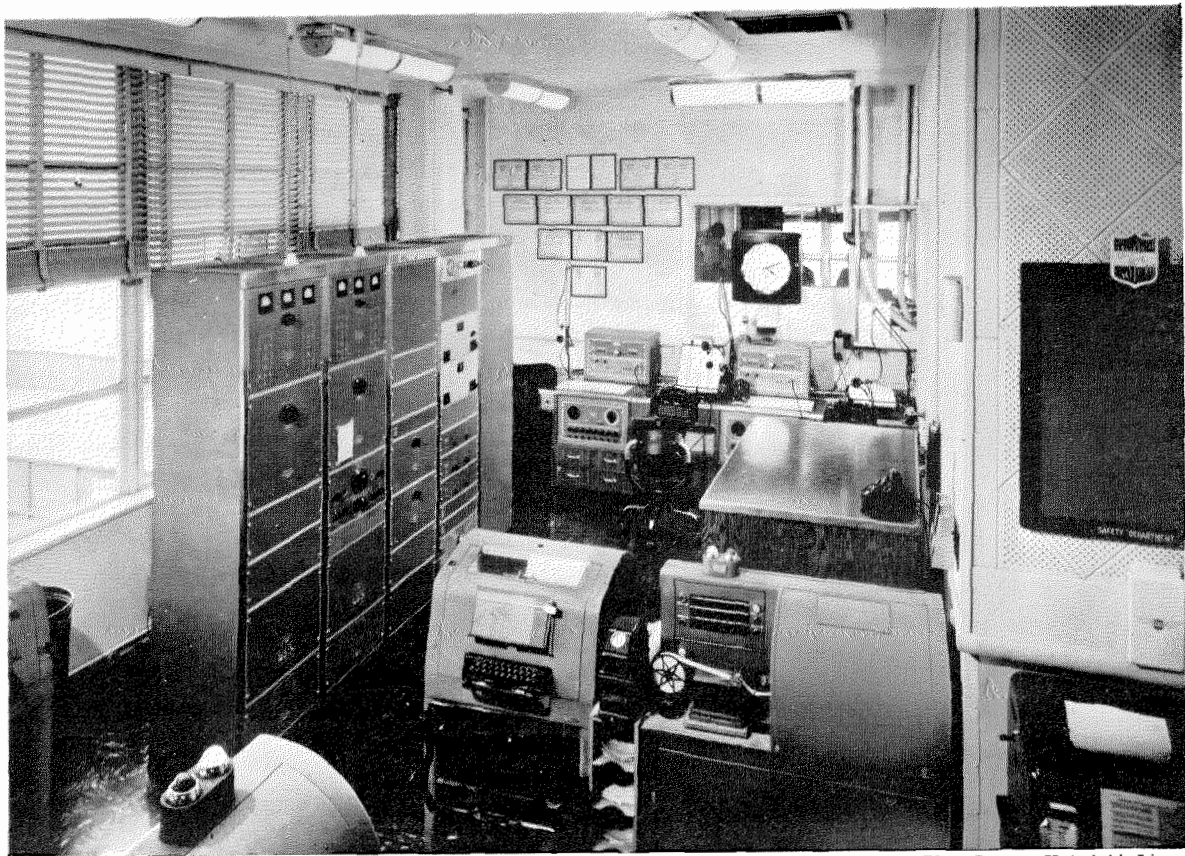

Photo Courtesy United Air Lines

Fig. 9—Portland, Oregon, switching center showing radio section.

Multiple Transmission

Each reperator switching center on the system is equipped with a "Multiple" sending circuit. The multiple sending circuit provides facilities by means of which a message may be transmitted simultaneously to any selected group or to all of the sending circuits appearing at the center. When this circuit is used the switching operator plugs the message up to the multiple sending jack, then selects, by means of individual switches, the circuits to which she wants the message to go. After the selection is made, a start switch is operated to start operation of the tape transmitter. If any of the selected circuits are busy, switching relays delay the start of the tape transmitter until all of the busy circuits have completed their messages. The multiple sending circuit then connects and at

the completion of the message disconnects automatically and all selected circuits are released immediately for traffic from other tape transmitters or keyboards.

Duplex and Single Circuits

All of the long-distance trunk circuits on the network are operated by the "Duplex" method. On duplex circuits, messages may be transmitted in both directions at the same time. Many of the short circuits and multi-station circuits, however, are operated "Single." On a single circuit, only one message may be transmitted at any one time. Control relays are provided at the switching centers to delay the start of a tape transmitter which has been plugged up to a busy single circuit until the traffic, in transit, has been completed.

Switching Center

As an example of the layout of equipment in a switching center, two views of the Portland, Oregon, center are shown by Figs. 8 and 9. Fig. 8 shows the reperforator switching section and Fig. 9 shows the radio section.

In the reperforator switching section, the sending teleprinters can be seen lined up against the windows. The tall cabinet in this line contains monitoring equipment and the apparatus associated with the multiple sending circuit. The selecting switches for the multiple sending circuit are on the face of this cabinet. Across the aisle are the printer perforator consoles where all incoming messages are received and switched. The message filing cabinet is shown in the rear of the room.

On the radio section photograph, Fig. 9, can

be seen the front view of one printer perforator console in the foreground. This printer perforator is connected electrically to the keyboard of the teleprinter located to the left and is used for local transmission from the center. The teleprinter is a local receiving teleprinter which provides printed copies of messages for local delivery.

These pictures of the Portland center could be applied with minor variations to any of the other six reperforator switching centers on the United Air Lines system. The important feature at all of the switching centers, of course, is the speed and accuracy provided by the reperforator switching method of relaying telegraph traffic. This feature is a fitting and necessary complement to the fast flight schedules maintained by United Air Lines planes in flying a total of more than 100,000 miles per day.

Electron Trajectories in a Plane Diode—A General Result

By LÉON BRILLOUIN

Columbia University, New York, N. Y.
Consulting Engineer, Federal Telephone and Radio Laboratories, New York, N. Y.

Summary: A general result of great importance—it might be called a theorem of electronics—is formulated in this article. It is directly related to the theory developed in a previous article,¹ which was based on the Llewellyn method of solution of electronic motions, and involves the shape and the relative disposition of the trajectories of electrons emitted by the cathode, and the fact that these trajectories do not cross each other.

In a plane diode with hot cathode and space charge operated under arbitrary voltage variation as a function of time, it is shown that electron trajectories never cross each other provided electronic emission on the cathode is continuous and the current does not become negative. If, however, the current is negative during a certain time interval, there is a possibility that electrons falling back on the cathode may cross electrons emitted from the cathode. Such crossing apparently happens only for very few electrons and, in most cases, probably can be ignored. The situation is radically different for electrons emitted with a finite velocity.

1. Introduction

IN A PLANE diode with hot cathode and space charge, operated under arbitrary voltage variation as a function of time, electron trajectories never cross each other provided the current never becomes negative. The case of negative currents will be discussed separately. This holds for space-charge limited, or temperature-limited, current. The same result should apply to a cylindrical diode but, if a magnetic field is acting on the electrons, entirely different conditions prevail.

This conclusion is fundamental and justifies the Llewellyn method applied to the diode. The essential point in the method is equation (9) of a previous article:

$$\frac{dE}{dt} = \left(\frac{\partial E}{\partial t} \right)_x + \dot{x} \frac{\rho}{\epsilon_0} = \frac{1}{\epsilon_0} J(t),$$

implying that, at every point within the space charge, electrons all flow in the same direction with velocity \dot{x} .

This assumption is by no means obvious. In many electronic problems, it has been found that two streams of electrons, flowing in different directions, cross each other in some regions of the space charge. If this happens, the above equation can no longer be used since the velocity $\dot{x} = \frac{dx}{dt}$ of the electrons is not completely defined and may possess two different values.

In the plane diode without magnetic field, it will be shown that, under no circumstances, can an electron trajectory cross the next trajectory. Electron beams emitted by the cathode always travel in the same sequence and never overlap. Successive layers of electrons, in fact, maintain a constant stratification, regardless of variation of applied anode voltage, provided positive current be maintained.

2. Mathematical Proof

Starting from equation (10) of the previous article, which gives at time t the field $E(t_0, t)$ acting on electrons that leave the cathode at t_0 ,

$$E(t_0, t) = \frac{1}{\epsilon_0} \int_{t_0}^t J dt + E_0(t_0), \quad (1)$$

where $E_0(t_0)$ is the electric field on the cathode at the time t_0 when electrons are emitted. It should be noted that—

Space-charge limited current means: $E_0 = 0$.

Temperature limited current means: $E_0 < 0$.

We introduce the following notations:

$$\begin{aligned} \frac{e}{m\epsilon_0} \int_0^t J dt &= F(t), \\ \int_0^t F(t) dt &= F_1(t), \\ \int_0^t F_1(t) dt &= F_2(t). \end{aligned} \quad (2)$$

¹ "Transit Time and Space-Charge in a Plane Diode," by Léon Brillouin, *Electrical Communication*, Vol. 22, No. 2, 1944.

The equations of motion of electrons are given in equations (11) and (12) in the article cited, and must be integrated with the initial conditions.

$$t = t_0, \quad x = 0, \quad \dot{x} = 0. \quad (3)$$

Hence the solution:

$$\begin{aligned} \ddot{x} &= \frac{e}{m} E(t_0, t) = F(t) - F(t_0) + \frac{e}{m} E_0(t_0), \\ \dot{x} &= F_1(t) - F_1(t_0) - \left[F(t_0) - \frac{e}{m} E_0(t_0) \right] (t - t_0), \\ x &= F_2(t) - F_2(t_0) - F_1(t_0)(t - t_0) \\ &\quad - \left[F(t_0) - \frac{e}{m} E_0(t_0) \right] \frac{(t - t_0)^2}{2}. \end{aligned} \quad (4)$$

This yields x as a function of t and t_0 . What we want to compare is the relative position at time t of two electrons emitted at t_0 and $t_0 + dt_0$.

Hence we compute the partial derivative $\left(\frac{dx}{dt_0}\right)_t$ taken at constant t .

$$\begin{aligned} \left(\frac{dx}{dt_0}\right)_t &= -\frac{dF_2}{dt_0} + F_1(t_0) - \frac{dF_1}{dt_0}(t - t_0) + F(t_0)(t - t_0) \\ &\quad - \frac{e}{m} E_0(t - t_0) - \left[\frac{dF}{dt_0} - \frac{e}{m} \frac{dE_0}{dt_0} \right] \frac{(t - t_0)^2}{2}. \end{aligned} \quad (5)$$

As defined in (2), the terms in the first row cancel each other, and $\frac{dF}{dt_0}$ equals $\frac{e}{m\epsilon_0} J(t_0)$; hence,

$$\begin{aligned} \left(\frac{dx}{dt_0}\right)_t &= -\frac{e}{m} E_0(t - t_0) \\ &\quad - \frac{e}{m\epsilon_0} \left[J(t_0) - \epsilon_0 \frac{dE_0}{dt_0} \right] \frac{(t - t_0)^2}{2}. \end{aligned} \quad (6)$$

For *space-charge limited* current E_0 , $\frac{dE_0}{dt_0}$ is zero, and the current $J(t_0)$ at the moment when electrons leave the cathode is obviously negative; e also is negative, so that

$$\left(\frac{dx}{dt_0}\right)_t < 0. \quad (7)$$

The successive layers of electrons emitted by the cathode travel through the space-charge in the same sequence and follow each other with no overlapping.

For *temperature limited* current E_0 is negative, which makes the first term of (6) negative.

Moreover, $J_0 - \epsilon_0 \frac{dE_0}{dt_0}$ represents the electronic current leaving the cathode at t_0 (total current minus displacement current) and this is negative, yielding a negative second term.

Hence, in any case, the derivative $\left(\frac{dx}{dt_0}\right)_t$ is negative; its absolute value increases with the transit time $T = t - t_0$. Electron trajectories diverge with increase of time.

This justifies the use of the equations cited from the previous paper (9) and the general formula (34) for computation of the voltage. The latter formula contains the derivative $\left(\frac{dE}{dT}\right)_t$ which, but for a factor $\frac{e}{m}$, is the same as $\left(\frac{dx}{dt_0}\right)_t$.

It could not be used if this derivative did not maintain a constant sign.

As stated previously, no assumption has been made regarding the law of variation of current and voltage as functions of time.

3. Discussion of the Validity of This Result

A brief discussion will clarify the actual situation and the conditions of validity of the theorem. What has been proved is exactly:

If electronic emission is continuous and no crossing recurred before time t , then it will never happen afterwards.

In other words, if we take a cold diode, or a diode with no anode voltage so that there is no space charge at the beginning, and if we start operating the diode continuously, there will never be any crossing of trajectories.

But if there be an arbitrary motion of electrons in the diode at the beginning, with electrons flowing in unknown directions, our proof no longer applies and nothing can be deduced from it. In such a case, the difficulty results from the fact that, at time t_0 , electrons may be returning toward and emitted from the cathode simultaneously. Thus the sign of the total resulting electronic current cannot be determined, i.e., the expression playing a fundamental role in our discussions of equations (6) and (7). The implicit assumption was that no crossing or overlapping ever occurs at times $t_0 < t$ so that, at the moment of emission, there would be only a one-way flow of electrons from the cathode, meaning a positive electronic current.

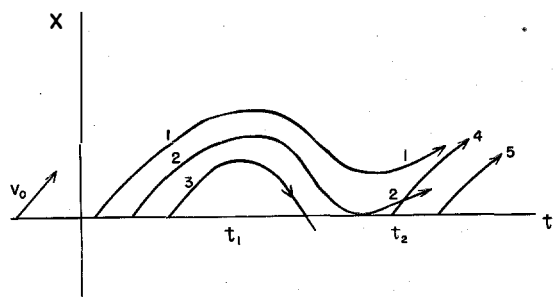

Fig. 1.

Let us consider another example illustrating conditions in a case that might be critical. Assume that electrons are emitted from the cathode up to time t , then that they fall back upon the cathode from t_1 to t_2 when a new flow of electrons starts leaving the cathode. Electron trajectory paths are supposed to resemble the ones shown in Fig. 1.

Electron 1 oscillates without falling back on the cathode. Electron 2 touches the cathode at t_2 and reverses its motion; hence its velocity at t_2 must be zero. Electron 3 falls back on the cathode, while 4 is emitted after t_2 .

We have proved that two electrons emitted at t_0 and $t_0 + dt_0$ never cross each other. Trajectories 1, 2, and 3 never cross—but what about 2 and 4? These have been emitted at t_{02} and t_{04} after a long time interval and our proof does not seem valid. However, since electron 2 returns to the cathode at t_2 we may consider it as “re-emitted” at $t_{02}' = t_2$ and t_{02}' , t_{04} being very near, our proof is valid again showing that trajectories 2, 4 do not cross each other.

This exposition is based on the relations assumed in Fig. 1, but the disposition of the curves is by no means certain. One can imagine electrons still falling back on the cathode at a time when the field on the cathode becomes negative ($eE > 0$) with emission already started. In other words, emission may begin before time t_2 of Fig. 1.

Let us take an example to determine the actual conditions. A typical case is represented by the following current law:

$$I = -at + bt^3 \tag{8}$$

which gives a short positive current impulse for

negative t followed by a negative current impulse and a new rise in current. By a convenient change in the I and t scales, the curve can be reduced to a standard shape

$$\frac{e}{m\epsilon_0}I = -2t + 3t^3, \tag{9}$$

which yields

$$\begin{aligned} F &= -t^2 + t^4, \\ F_1 &= -\frac{t^3}{3} + \frac{t^5}{5}, \\ F_2 &= -\frac{t^4}{12} + \frac{t^6}{30}. \end{aligned} \tag{10}$$

All these curves are shown on Fig. 2. From these functions the field $E(\theta, t)$ and the position $x(\theta, t)$ of the electron leaving the cathode at θ can be computed. Assuming no saturation, $E_0 = 0$, eq. (4) yields

$$\begin{aligned} \frac{e}{m}E(\theta, t) &= F(t) - F(\theta), \\ x(\theta, t) &= F_2(t) - F_2(\theta) - F_1(\theta)(t - \theta) \\ &\quad - \frac{1}{2}F(\theta)(t - \theta)^2. \end{aligned} \tag{11}$$

Some trajectories were computed and the curves drawn on Fig. 3. Electrons falling back on the cathode were emitted between $\theta \approx -.26$ and

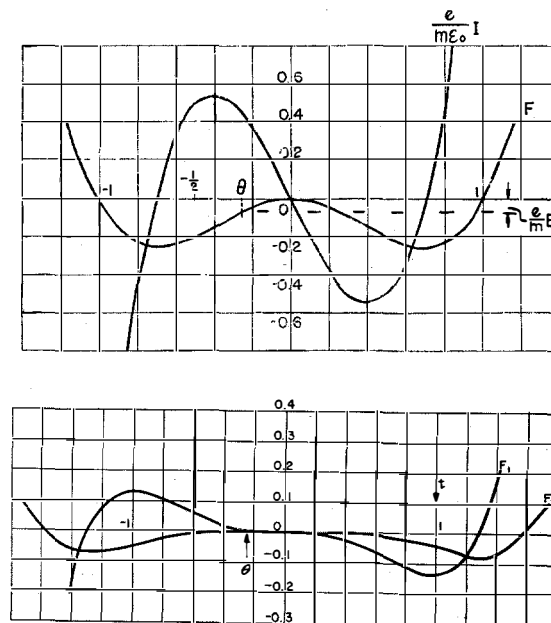

Fig. 2.

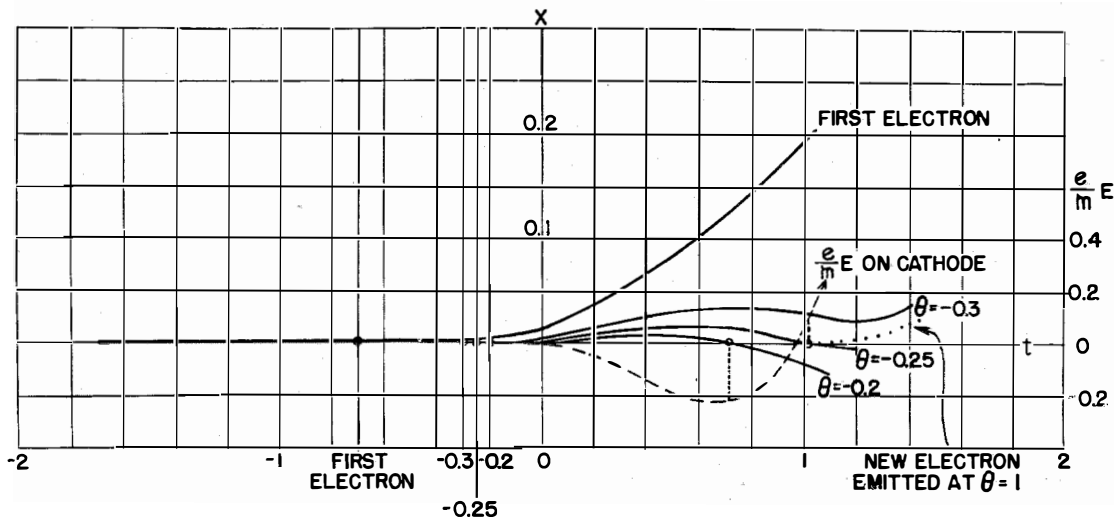

Fig. 3.

$\theta=0$. For $\theta=-.25$ the electron reaches the cathode at $t=1.01$ with a small negative velocity. The electron emitted at $\theta=-.30$ passes at a distance from the cathode.

The field on the cathode, at the moment one electron returns to the cathode, can be obtained from eq. (11) and is plotted as a dashed curve on Fig. 3. For $0 < t < 0.5$, the curve is almost identical with the $F(t)$ curve of Fig. 2, which means that the negative current I is largely displacement current with only a small electronic current. A similar situation was found in the previous paper (Fig. 4) where electronic back current amounted only to $1/9$ of the total negative current. The ratio is very nearly the same in the example of Fig. 3. Trajectories were computed for $\theta=-.2$, $-.25$ and $-.3$, two of which impinged on the cathode and gave two points of the $\frac{e}{m}E$ curve. It can be seen that $\frac{e}{m}E$ on the cathode becomes positive for $t > .97$ approximately. So eE is positive when the electron $\theta=-.25$ comes back upon the cathode at $t=1.01$, but it is a near miss, and very few electrons are able to reach the cathode at instants of time when E is positive. The trajectories $\theta=-.25$ and $\theta=-.3$ have their minimum near $t=1.2$. Hence the last electron to reach the cathode is the one leaving at $\theta \approx -.26$ and returning at $t=1.2$.

Mathematically considered, it is possible that electrons keep falling back on the cathode after electronic emission from the cathode has started. This means that some electronic trajectories cross each other, and the Llewellyn method of integration would not apply since it is based on the assumption of non-crossing trajectories. New emission from the cathode would prevent the field from developing and it would remain zero on the cathode after $t=.97$.

Practically considered, this difficulty would seem to occur for very few trajectories, and only for the very last electrons returning to the cathode. This suggests that no great error would be introduced by simply ignoring these exceptional cases.

At the end of an interval with negative current, it is possible that the last electrons falling back on the cathode may slightly disturb the new electrons starting from the cathode. The resulting perturbation, however, is likely to be very slight. It seems that conditions actually are very close to those represented on Fig. 1, where the new emission was assumed to follow immediately the last electron falling back on the cathode. The trajectory of a new electron emitted at $\theta=1$ (the first one of the new emission) is shown as a dotted curve on Fig. 3, and circumstances make it very flat, being almost the continuation

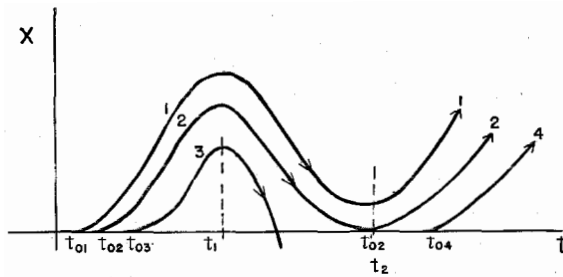

Fig. 4.

of our previous electron $\theta = -.25$. Hence the deviation from Llewellyn's theory should actually be very small.

4. Extension and Generalization

The proof given in the preceding sections covers the case of electrons emitted without initial velocity. Let us now examine the case of electrons emitted with an *initial velocity* $V_0(t) > 0$ and its effect on our conclusions.

The introduction of an initial velocity $V_0(t)$ results in adding some new terms in our formulae:

$$\left. \begin{array}{l} \dot{x}: \text{new term added } V_0(t_0), \\ x: \text{new term added } V_0(t_0)(t-t_0), \end{array} \right\} \quad (4-a)$$

$$\left(\frac{dx}{dt} \right)_t: \text{new term added } -V_0(t_0) + \frac{\partial V_0}{\partial t_0}(t-t_0). \quad (6-a)$$

If electrons be emitted from the cathode with a constant uniform velocity V_0 , our general result still holds and $\left(\frac{dx}{dt} \right)_t$ is always negative. This is true for any arbitrary current or voltage variation. But the general proof no longer applies if the *initial velocity is a function of time*, since the sign of the term in $\frac{\partial V_0}{\partial t_0}(t-t_0)$ is unknown. Thus crossing of trajectories and overlapping of electron beams become a possibility—corresponding to “velocity modulated” beams.

Even in the case of a constant initial velocity, the example discussed at the end of section 3 (Figs. 1 and 3) requires special attention.

If we draw Fig. 4, similar to Fig. 1, but with a constant initial velocity $V_0 > 0$, trajectories 2 and 4 must cross each other since electron 2 returns to the emitting electrode and reaches it with zero velocity, while electron 4 leaves the same electrode with finite velocity and certainly must overtake 2 speedily.

In the case of *electrons emitted with finite velocity, no crossing or overlapping occurs provided the motion of electrons is such as never to bring them back on the emitting electrode*. This is a rather severe restriction.

The problem here considered is the one of an electron beam travelling in the interval between grid and anode or between two grids. Crossing or overlapping are synonymous with bunching; our discussion shows the circumstances that make bunching possible when space change effects are taken into account.

In joining successive intervals separated by grids, the mathematical conditions representing an “ideal grid” must be recognized. They include:

- Continuity of the voltage,
- Discontinuity of field and total current,
- Eventually continuity of the electronic part of the current in case the grid does not collect any electron (negative grid).

It should be emphasized that, even for a negative grid, a current discontinuity occurs since a discontinuous field means a discontinuous displacement current. In each interval between two successive grids, Llewellyn's method can be applied (provided there is no bunching) with a different total current $J(t)$ in each, and a discontinuity of J at the plane of the grid.

The Barkhausen tube with positive grid and low-voltage plate provides a typical example of the problem just discussed. When such a tube is oscillating, electron trajectories must certainly cross each other near the grid as shown on Fig. 4.

Schottky's Theories of Dry Solid Rectifiers

By J. JOFFE, Ph.D.

Professor in Chemical Engineering, Newark College of Engineering, Newark, New Jersey

Editor's Note: Following a brief introduction, this article summarizes W. Schottky's views on rectification as expounded in a series of papers published during the years 1939 to 1942, inclusive. The manuscript was prepared by Dr. Joffe in 1944 while on the staff of the Rectifier Division, Federal Telephone and Radio Corporation, and on a leave of absence from the Newark College of Engineering.

THE two most important technical developments dependent on the rectifying action of a contact between semiconductor and metal, a phenomenon known since 1874, are the cuprous oxide and selenium rectifiers. Many papers have been published and various theories advanced to explain their rectifying action. Any successful theory, however, had to await the formulation of a valid theory of electronic conduction in metals and semiconductors.

The modern theory of electron conduction¹ assumes the presence in a crystal of energy levels comprising electrons. Such energy levels have been postulated in the quantum theory for the electrons of a single isolated atom. Energy levels in an isolated atom, as a rule, are spaced far apart; contrariwise, energy levels in crystals occur in bands of very closely spaced levels, and the bands are separated by regions containing no energy levels. According to the quantum theory each level at most can accommodate two electrons, the lowest levels being filled first. If the energy levels of a band are completely filled with electrons, while the accessible adjacent band is completely empty, the crystal behaves as an insulator. In this case a moderate external electric field can produce no current; there are no vacant levels to which the electrons can be transferred except in the next higher band—a transfer that would require an enormous potential gradient. In the case of an energy band not completely filled with electrons, an electric field causes redistribution of the electrons over the energy levels and so produces an electric current.

The crystal is then a metal. When a band is nearly full, the electrons responsible for conduction behave in an anomalous manner. The conduction mechanism is then best described in terms of the motion of vacant spaces in the band or "holes." These "holes" behave like positive charge-carriers having the mass of electrons. It is possible to determine from measurements of the Hall and thermoelectric effects whether the current in a given conductor is carried by electrons in the normal way or by positive "holes."

Semiconductors are a class of substances that owe their electronic conductivity to the presence of impurities or lattice imperfections. The semiconductor itself possesses a lower energy band completely filled with electrons and an upper one which is empty. The intrinsic conductivity of the semiconductor is similar in nature to that of an insulator and is due to the relative scarcity of electrons that possess sufficient thermal energy to pass from the lower band into the upper normally empty one. Their number is given by a function of the form $e^{-b/T}$, where b is proportional to the energy difference between the bands and T is the absolute temperature. Impurities in a semiconductor possess energy levels which fall in the region between the two bands of the semiconductor and which may act as donors of electrons to the upper band. The energy step then becomes small enough to permit appreciable electronic conductivity at room temperature. Such a semiconductor is referred to as an "excess conductor" since the current is carried by electrons in a nearly empty band. On the other hand, the energy levels corresponding to the impurity

¹ See References at end of article.

atoms may accept electrons from the lower band of the semiconductor. Holes are thereby created in the band, their number depending on the energy step between the lower band and the energy level of the impurity. Current is then carried by the "positive holes" in the semiconductor which is said to be a "defect conductor." Cuprous oxide and selenium are both regarded as "defect conductors."

Attempts to explain rectification at the boundary between metal and semiconductor, based on modern theories of electronic conduction, were made independently in 1932 by A. H. Wilson, by Nordheim, and by Frenkel and Joffe. These investigators pictured the metal and semiconductor as separated by a potential barrier. Electrons were assumed to pass through the potential barrier in either direction by the well-known tunnel effect. The direction of easy flow of electrons would be from metal to semiconductor. For a "defect conductor," however, the direction of easy flow would be reversed. This theory fails because it predicts rectification in the wrong direction. Thus, in cuprous oxide, a "defect conductor," the direction of easy flow is that of positive current from cuprous oxide to copper.

In 1939 N. F. Mott² proposed a crystal rectifier theory in which he assumed a potential barrier between metal and semiconductor sufficiently thick so that electrons could not go through it by the tunnel effect. The electrons would then have to pass over the barrier by thermal excitation. In his treatment he made a number of assumptions, the chief limitation being that the space charge in the region of the potential hump may be neglected so that the potential gradient in this region would be constant. Mott arrived at a function for the current giving the correct direction of rectification and, after introducing a correction for the Schottky field emission effect, obtained approximate agreement with experimental characteristics of cuprous oxide rectifiers.

Qualitative Aspects of Schottky's Theory

W. Schottky in a series of papers^{3,4,5,6,7} beginning in 1939 attacked the problem somewhat in the same manner as Mott, assuming a potential hill extending from the metal into the semiconductor. Schottky, however, placed great emphasis on the space charges formed in the

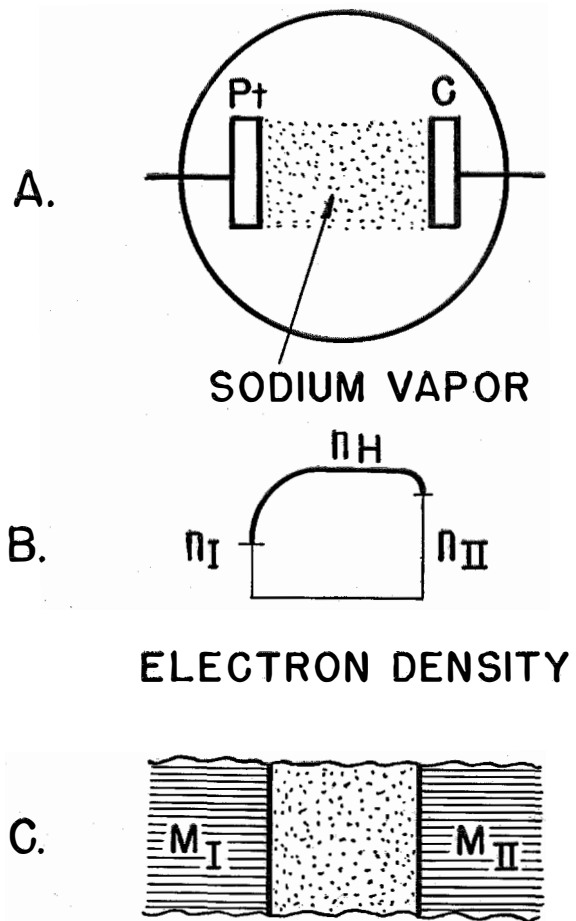

Fig. 1—(a) Thermionic analogy, Pt, C electrodes and sodium vapor; (b) Curve showing distribution of electron density in semiconductor; (c) Diagram showing semiconductor with uniform concentration of impurity centers, placed between metal electrodes M_I and M_{II} .

boundary layer² of the semiconductor in contact with the metal and their effect on the potential profile and on conductivity. In his first paper,³ using thermionic analogies, he considered one of the simpler cases, i.e., that of a semiconductor with uniformly distributed dissociating impurity spots in contact with two metal electrodes. The semiconductor, in the thermionic analogy, corresponds to space filled with an ionizable gas, such as sodium vapor, and the metal electrodes to the electrodes of a thermionic tube. Just as in the latter the work-function, metal-vacuum, determines the electron density in the immediate neighborhood of the metal electrode, the ideal rectifier work-function, metal-semiconductor,

determines the electron density in the semiconductor at the metal boundary. Corresponding to the two metals, *I* and *II*, the two boundary electron densities are n_I and n_{II} . In the interior of the semiconductor an electron density, n_H , is determined by the dissociation of impurity centers and by the requirement of neutrality (Fig. 1). At the boundaries between semiconductor and metal electrodes there exists a space charge density, determined by the difference between the existing electron density and that which would prevail under neutral conditions, i.e., $\rho = e \times (n - n_H)$. The space charge is related to the potential gradient F and to the potential V by the well-known Poisson relations $\frac{dF}{dx} = \frac{4\pi\rho}{\epsilon}$, $\frac{d^2V}{dx^2} = -\frac{4\pi\rho}{\epsilon}$, $\epsilon =$ dielectric constant.

The boundary layers in which these space charges are present exhibit a non-ohmic resistance while the interior of the semiconductor, where $n = n_H$, acts as an ohmic resistance. Further, if $n_H > n_{II} > n_I$, there is a smaller boundary resistance at metal electrode *II* than at metal electrode *I*, so that the non-ohmic effects at the two metal boundaries do not cancel each other. The effect of current in the blocking direction on the space charge distribution and thickness of the boundary layer can be determined by assuming a steady state with pure field flow (neglecting diffusion currents); the current strength then must be constant with respect to the position coordinate. Hence $F \times n = \text{const.}$, where n , the electron density, is assumed to be proportional to the conductivity. The field strength F , the space charge ρ , and the potential V are in turn related by Poisson's equation. An increase in current requires an increase in F and in the differences in F as we progress from boundary to semiconductor interior. This means an increase in the space charge in the boundary layer. Since, however, the space charge density is limited by the fixed bound n_I or n_{II} , an increase in the total charge in the boundary layer can be brought about only by an increase in the width of the layer. The resistance of the boundary layer consequently increases with the current.

If, subsequently, under the action of an external field, current is made to flow in the opposite direction with electrons moving from semicon-

ductor to metal, a steady state with pure field flow cannot be attained in the boundary layer where electron impoverishment exists. Instead the boundary layer must contract until the rate of decrease of n at the boundary becomes sufficiently steep for diffusion to carry electrons through the boundary layer to the metal. As the boundary layer contracts, the boundary resistance correspondingly decreases. The fundamental equation for a steady state of current flow through the boundary layer is

$$i = eb n F \pm eb B \frac{dn}{dx}$$

Here e is the electronic charge, b the mobility, n the electron concentration or density, F the field strength, $B = \frac{kT}{e}$ where k is the Boltzmann constant and T the absolute temperature and $\frac{dn}{dx}$

the concentration gradient. The first term on the right of the equation represents field flow and the second term the diffusion current. The minus sign in the equation holds for "defect conductors" in which conduction is by "positive holes."

The same equation was used by Mott. In his treatment, however, Mott integrated the equation on the assumption that F is constant, whereas Schottky and Spence⁴ consider the variation of F with space charge density according to the Poisson equation, $\frac{dF}{dx} = \frac{4\pi\rho}{\epsilon}$. It is shown by Schottky that in his treatment, just as in Mott's theory, the direction of rectification for a "defect" semiconductor is the reverse of that of an "excess" semiconductor, i.e., the easy direction of flow is that of positive holes in the direction from semiconductor interior toward the metal.

The blocking effect in the boundary layer of a semiconductor so far considered may be described as *physical* since it depends entirely on the existence of space charge in the boundary layer which, in every other respect including distribution of impurity centers, does not differ from the interior of the semiconductor. Nevertheless, a boundary layer of a semiconductor may differ from the semiconductor interior in that it may possess much smaller concentration of impurity centers—a prerequisite for what Schottky calls a chemical barrier layer. As explained

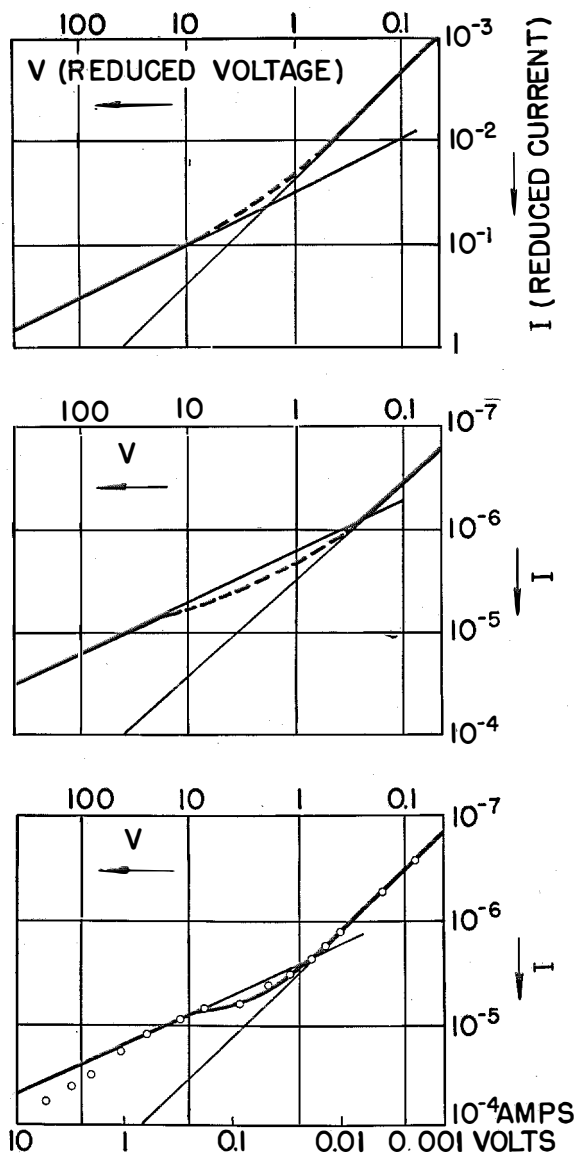

Fig. 2—Characteristics in blocking direction: (a) "Reserve" boundary layer; (b) "Exhaustion" boundary layer; (c) Experimental curve for (high-voltage) cuprous oxide rectifier.

previously, when the current in the blocking direction is increased, the space charge in the boundary layer must increase. This can occur through an increase in the width of the space charge zone or through an increase in space charge density. Adjoining the chemical barrier layer is a region of relatively large impurity center concentration in which (say, through dissociation of the impurity centers) a high

space charge density can be established. Hence, the width of the space charge zone will never appreciably exceed the width of the chemical barrier layer, i.e., the region of impurity center impoverishment. A region extending beyond the space charge zone, on the other hand, must exhibit a pure ohmic resistance regardless of its impurity center content. It may be surmised that the optimum of technical rectification is obtained when the thickness of the chemical barrier layer is of the same order of magnitude as the width of the space charge zone. Thus, according to Schottky, the width of the boundary layer predicted by space charge theory is 10^{-6} to 10^{-3} centimeters, depending on the conductivity assumed in the semiconductor interior. Capacity measurements on cuprous oxide and selenium rectifiers indicate boundary layers of 10^{-5} to 10^{-4} centimeter thickness, a similar order of magnitude.

Schottky places in a different class artificial barrier layers, such as organic lacquer layers applied between semiconductor and metal electrode. Microscopic holes in such layers permit contact between metal and semiconductor, thus giving in effect a multiple point-contact rectifier with fine and widely separated point contacts. In such arrangements the ohmic resistance is particularly small as compared to the non-ohmic boundary resistance and hence especially good rectification is obtained. Invisible high-resistance layers on the surface of the semiconductor or metal electrode (say, oxides) may act in a manner similar to artificial blocking layers by reducing the contact area between metal and semiconductor.

Results of Schottky's Mathematical Analysis

Let us return now to a more thorough consideration of Schottky's space charge theory. In the paper by Schottky and Spence,⁴ in which the theory is formulated quantitatively, two limiting cases are considered. In the first, the fraction of dissociated or ionized impurity centers is small. The electron density (for "excess" conductors) is then inversely proportional to the concentration of ionized impurity centers. A layer in which this relation holds is referred to by Schottky as a "reserve" layer. The second limiting case is

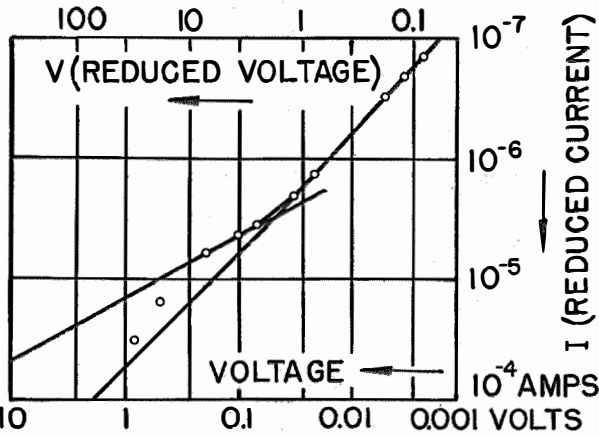

Fig. 3—Characteristic in blocking direction for a commercial selenium rectifier.

that where practically all the impurity centers are ionized. This gives a positive space charge density (for "excess" conductors), practically constant and equal to the concentration of the impurity centers. A layer in which this condition exists Schottky designates as an "exhaustion" layer. The current-voltage characteristics for these two types of barrier layers are decidedly different in the blocking direction.

Fig. 2 shows the theoretical curves for the two cases as well as an experimental curve for a cuprous oxide rectifier (a reduced voltage as abscissa is plotted logarithmically against a reduced current as ordinate). Physically the difference between the two types may be explained as follows: As the current in the blocking direction is raised, the space charge in the blocking layer must increase. For the "reserve" type this is accomplished partly by an increase in the fraction of impurity centers which are ionized. Hence, there is only a moderate increase in the width of the space charge zone and in the boundary resistance. In the case of an "exhaustion" layer there can be practically no further increase in space charge density since practically all the impurity centers are already ionized. Hence, a relatively large increase occurs in the width of the space charge zone and, therefore, in resistance. Deviation from a 45 degree line is greater for the "exhaustion" type. As seen from the figure, the cuprous oxide rectifier approximates the "exhaustion" type. Current-voltage char-

acteristics obtained with selenium rectifiers at first made it appear that selenium blocking layers belong to the class of "reserve" layers (see Fig. 3). The work of Miss A. Schmidt⁸, however, showed the strong dependence of current-voltage characteristics of selenium rectifiers on the metal used as counter-electrode. Thus, the characteristic of a selenium rectifier with a bismuth-tin counter-electrode is typically of the "exhaustion" variety. Field emission effects are brought into play with the usual type of counter-electrode (cadmium-tin), masking the "exhaustion" character of the blocking layer.

Measurements made by H. Schweickert⁵ on the resistance of selenium rectifiers with counter-electrodes made of different metals are interesting. Fig. 4 shows resistance plotted against the work-function, metal-vacuum. There should be a close parallelism between the work-functions, metal-vacuum, and metal-semiconductor. The metal with the larger work-function should create the greater boundary impoverishment in

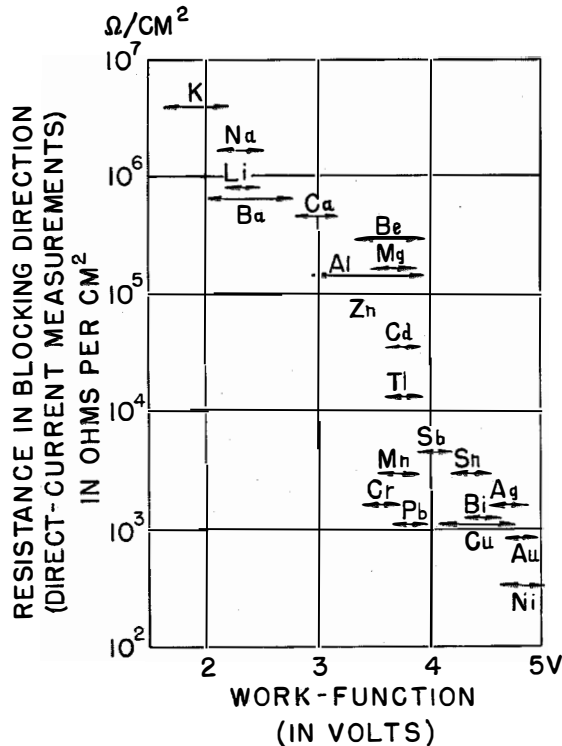

Fig. 4—Resistance in blocking direction of selenium rectifiers vs. work-function of metal.

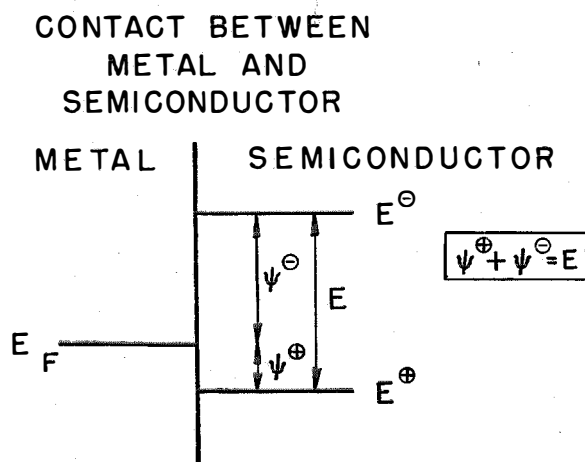

Fig. 5—Energy levels in metal and semiconductor.

electrons in the semiconductor and thus produce the larger boundary resistance. The anomaly in the case of selenium—larger work-functions producing smaller resistance—is explained by the fact that selenium is a “defect conductor.” The work-function for “positive holes” is complementary to the work-function for electrons, as can be seen from the energy level diagram of Fig. 5. When an electron is raised from the energy level E^{\oplus} (corresponding to a filled electron band) to the energy level E^{\ominus} (corresponding to a vacant band), the energy, E , expended in the process creates a conduction electron and a “positive hole” in the semiconductor. E_F represents the surface of the Fermi distribution in the metal. It is obvious from the diagram that the work-function for electrons, ψ^{\ominus} , and the work-function for positive holes, ψ^{\oplus} , must add up to the constant value E . Hence, metals with small work-functions, ψ^{\ominus} , have large work-functions, ψ^{\oplus} , and produce a strong impoverishment in positive holes in the selenium boundary layer, leading to a high boundary resistance. Inasmuch as selenium rectifiers with low resistance bismuth-tin counter-electrodes were shown to belong to the “exhaustion” type, commercial selenium rectifiers with cadmium-tin counter-electrodes, which produce greater boundary impoverishment (more complete ionization of impurity centers), would according to Schottky⁶ certainly be of the “exhaustion” type.

An “exhaustion” boundary layer with uniform distribution of ionized impurity centers is treated by Schottky in a more recent article,⁷ the mathematical exposition being simplified. Since the space charge density in the boundary layer must be constant and proportional to the concentration of impurity centers, the field strength, F , is a linear function of the position co-ordinate. The potential profile is parabolic, as seen from Fig. 6. Here A^- represents the negatively charged impurity center, ψ^{\oplus} the work-function for “positive holes,” l_k the thickness of the space charge layer, and V_D the “diffusion” potential between semiconductor boundary and interior, necessary to maintain the space charge distribution in the semiconductor when no current is flowing. With the aid of additional simplifying assumptions Schottky derives mathematical expressions for the current both in the forward and in the blocking direction.

An important consequence of the simplified theory is that the concentration of impurity centers in the boundary layer can be calculated from capacity measurements according to the equation $\frac{d(1/C^2)}{dU} = \frac{8\pi}{\epsilon \epsilon n_{A^-}}$ where U is the applied potential, C the capacity, ϵ the dielectric constant, e the electronic charge, and n_{A^-} the concentration of ionized impurity centers. For an “exhaustion” layer, n_{A^-} is approximately equal to n_A , the concentration of impurity centers. If the distribution of impurity centers in the boundary layer is not uniform, as in the case of a chemical barrier layer, the potential profile of Fig. 6 is no longer parabolic. The expression

$$\frac{d(1/C^2)}{dU} = \frac{8\pi}{\epsilon \epsilon n_{A^-}},$$

however, still holds. The value of n_A is obtained from the slope of the curve which results when $1/C^2$ is plotted against U . The value of x , the distance from the metal boundary corresponding to any given value of n_A , can be calculated from the capacity C according to the equation

$$C = \frac{\epsilon}{4\pi x}.$$

Capacity measurements made by Miss A. Schmidt⁸ on selenium rectifiers show that, just as for cuprous oxide rectifiers, the equivalent

circuit consists of a capacity and resistance in parallel and a small series resistance. The latter corresponds to the ohmic resistance of the selenium layer; the resistance and capacity in parallel, to the boundary layer. In Fig. 7 are shown the results of measurements with selenium rectifiers, one with a magnesium and the other with a bismuth counter-electrode. The counter-electrodes were produced by thermal evaporation of the metals in question. These results, indicating uniform distribution of impurity centers, are particularly significant in the case of the magnesium counter-electrode. The formation of a rectifying magnesium-selenide layer could not be excluded a priori. Such a layer, however, would have a capacity independent of the applied voltage, which is certainly at variance with the observed behavior. From the slopes of the lines in Fig. 7, the impurity center concentration can be calculated; the concentration for the magnesium-selenium rectifier is approximately 8×10^{15} particles per cc and for the bismuth-selenium rectifier it is 1.6×10^{16} particles per cc. The widths of the boundary layers, calculated from the capacities, are 3×10^{-5} and 1×10^{-5} centimeters, respectively, when no potential is applied. Another interesting consequence of Schottky's

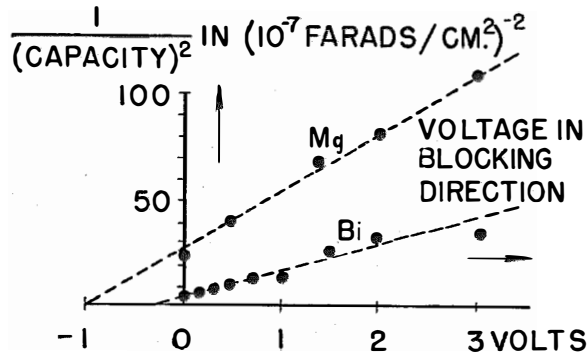

Fig. 7—Capacity of selenium rectifiers with magnesium and bismuth counter-electrodes vs. voltage in blocking direction.

equations is that the intercepts of the lines in Fig. 7 on the horizontal (voltage) axis give directly the values of the "diffusion" voltage V_D . The difference in the intercepts, as read from the figure, is about .7 volt. If in Fig. 6 the difference between the energy level of "positive holes" in the interior of the selenium layer and the level of the Fermi surface is assumed to be the same for the magnesium-selenium and bismuth-selenium rectifiers, then the difference in V_D for the two rectifiers must correspond to an equal difference in the work-function for "positive holes," ψ_{\oplus} . This, in turn, should correspond to a difference in the work-function for electrons, ψ_{\ominus} , in the opposite sense. Such a difference is actually observed, as can be seen from Schweickert's diagram, Fig. 4, which gives ψ (vacuum) = 3.6 volts for magnesium and ψ (vacuum) = 4.4 volts for bismuth, a difference of .8 volt.

A non-uniform distribution of impurity centers in the boundary layer can be inferred from capacity measurements when the counter-electrode is applied by cathodic sputtering. Fig. 8 shows the difference in results when a gold counter-electrode is applied by thermal evaporation and by cathodic sputtering. Fig. 9 shows the manner in which the calculated impurity center concentration varies with the distance from the metal boundary.

Values of V_D calculated from resistance measurements are in much poorer agreement with theory than those calculated from capacities. According to Schottky, field emission effects which cause the discrepancy have a much

METAL - SELENIUM BOUNDARY

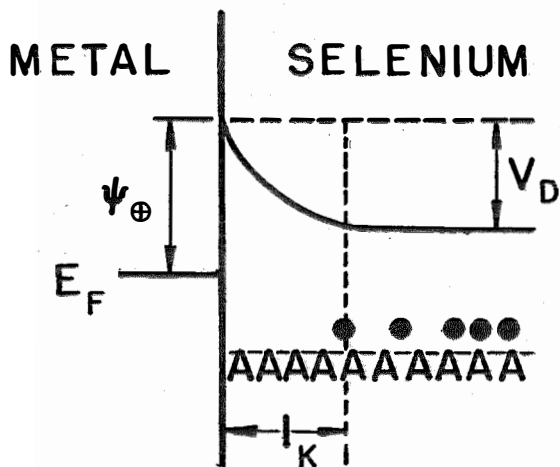

Fig. 6—Potential (ordinate) vs. distance (abscissa) from metal-selenium boundary showing layer of constant space charge density.

stronger influence on the conductivity than on the capacity of the boundary layer. Fig. 10 shows the current-voltage characteristics of a bismuth-selenium rectifier in the blocking direction: (a) calculated by B. Davydov's formula on the assumption of a "reserve" boundary layer⁹; (b) calculated by Schottky's method on the assumption of an "exhaustion" boundary layer; and (c) the observed curve.⁸ Schottky explains the deviation of curve (c) from (b) by field emission effects. The applied field not only lowers the potential barrier but also changes the electron density distribution and thus the conductivity in the boundary layer. Schottky's calculations, however, would indicate that only a small fraction of the current deviation from the theoretical value can be explained in these terms. His view is that the discrete nature of the space charge distribution is chiefly responsible for the deviations from thermal emission theory. Since impurity center concentrations in selenium rectifiers are of the order of 10^{16} per cm^3 and widths

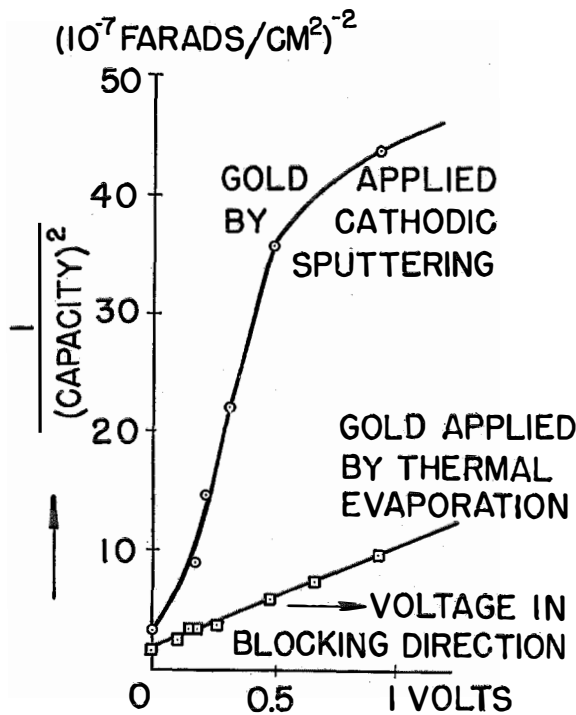

Fig. 8—Capacity of selenium rectifiers with gold counter-electrodes applied (a) by sputtering, (b) by thermal evaporation.

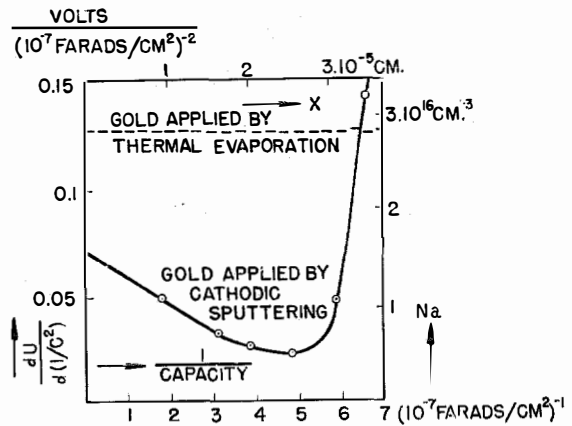

Fig. 9—Impurity center concentration n_A in selenium boundary layer (ordinate) vs. distance from gold counter-electrode (abscissa), X .

of boundary layers of the order of 10^{-5} cm, it follows that a boundary layer has a thickness corresponding to only about two to six layers of impurity centers.

Fig. 11 represents a hypothetical potential profile of such a boundary layer. (The dashed curve would hold for a continuous space charge distribution like the one assumed in Fig. 6.) Probability calculations, assuming random fluctuations, show that under these circumstances the concentration of impurity centers will be sufficiently high in certain locations in the boundary layer to overcome the potential hump and create a path for electrons. These electron paths only slightly affect the capacity of the boundary layer but greatly influence the resistance in the blocking direction, tending to lower it as the applied voltage is increased. Current leakage through these paths, as well as decreased resistance with increasing voltage, becomes relatively more pronounced at lower temperatures at which thermal emission is suppressed. For concentrations of impurity centers much in excess of 10^{16} per cm^3 electron paths lower the resistance of the boundary layer to such an extent that rectifying action is practically eliminated at room temperature. Concentration of 10^{16} impurity centers per cm^3 represents an extremely low value. Thus, for the bismuth-selenium rectifier, for which the calculated impurity center concentration is 1.6×10^{16} per cm^3 , there would be only one impurity

center for every two million selenium atoms. Schottky remarks that the combination of a sufficiently low concentration of impurity centers with a relatively high semiconductor conductivity is unusual, a circumstance that accounts for the rarity of good rectifying materializations. Schottky shows too how the simplified mathematical treatment developed for an "exhaustion" boundary layer can be applied to the cuprous oxide rectifier.⁷ In the latter the "exhaustion" layer is separated from the semiconductor interior by a "reserve" layer. Capacity measurements yield values for the thickness of the "exhaustion" layer instead of that of the entire boundary layer. Calculations of impurity center concentrations from capacity measurements on cuprous oxide rectifiers indicate a boundary layer impoverishment (chemical barrier layer), corresponding to concentrations of only about 4×10^{15} impurity centers per cm^3 and extending to a depth

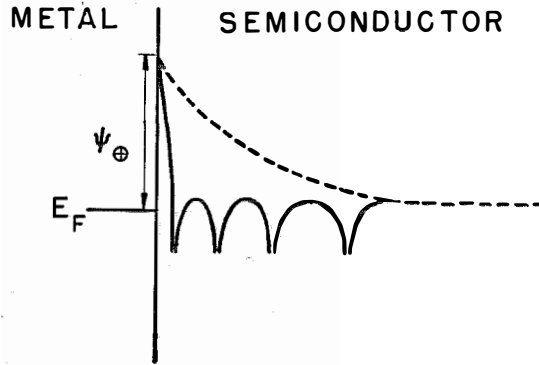

Fig. 11—Potential diagram for boundary layer with discrete (negative) point charges.

of about 6×10^{-5} cm. into the cuprous oxide. Beyond this depth the concentration quickly rises to values of over 10^{17} per cm^3 . However, the space charge layer attains a width of 6×10^{-5} centimeters only when the applied potential in the blocking direction reaches about .7 volt. Hence, for potentials under .7 volt, the rectifier behaves both with respect to direct and alternating currents as if it had a boundary layer with a uniform impurity center concentration and a variable thickness depending on the applied potential. According to Schottky, the assumption of a chemical barrier layer of constant thickness yields the better approximation provided the applied voltage in the blocking direction exceeds one volt.

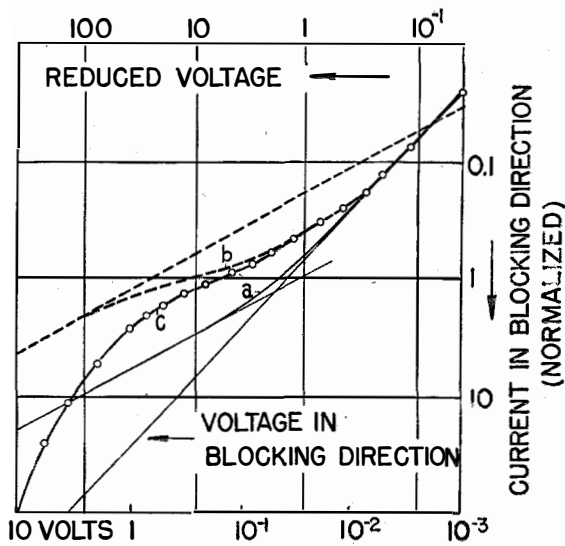

Fig. 10—Current (ordinate)—Voltage (abscissa), Characteristics of a selenium rectifier with bismuth counter-electrode.

References

1. See, for example, A. H. Wilson, "Semi-Conductors and Metals," 1939.
2. N. F. Mott, *Proc. Roy. Soc.*, 171A, 27, 1939.
3. W. Schottky, *Zeitschr. fur Phys.*, 113, 367, 1939.
4. W. Schottky and E. Spenke, *Wiss. Veroeff Siemens-Werke*, 18, 225, 1939.
5. W. Schottky, *Phys. ZS.*, 41, 570, 1940.
6. W. Schottky, *Schweizer Archiv.*, 7, 20-29, 82-86, 1941.
7. W. Schottky, *Zeitschr. fur Phys.*, 118, 539, 1942.
8. A. Schmidt, *Zeitschr. fur Phys.*, 117, 754, 1941.
9. B. Davydov, *Journ. of Phys.*, U.S.S.R., 4, 335, 1941.

Developments in Carrier Telegraph Transmission in Australia*

By R. E. PAGE, A.M.I.E.(Aust.) and J. L. SKERRETT

Foreword by R. E. Page, A.M.I.E.(Aust.)

THE introduction of the first carrier telegraph system into Australia in 1927 marked a considerable advance in the methods of providing and working the more important telegraph circuits between the capital cities of the Commonwealth. This first system, a Western Electric type "B," of 10 channels, was installed between Melbourne and Sydney in 1927, some two years after the first three-channel carrier telephone system had been placed in service between the two capitals, and is still in operation, carrying important circuits between those two centres.

The success of the type "B" system in providing a number of comparatively high speed, but more particularly, stable and readily controlled, telegraph channels, superimposed over one physical line, led to the early installation of further similar systems between the other state capitals: Sydney-Brisbane, Melbourne-Adelaide, and Adelaide-Perth. These systems then became the principal media for the transmission of telegraph traffic between the mainland capitals of the Commonwealth. With the advent of the type "B" system, the traffic handling methods tended to develop into the extraction of the utmost carrying capacity from each channel, and large volumes of traffic were shifted over long distances by machine telegraph systems. The Murray Multiplex system was used, the quadruple multiplex between adjacent capitals and triple multiplex where two links were used in tandem.

The capabilities of these methods in disposing of heavy telegraph traffic loads are demonstrated by the fact that until as recently as June, 1942, the carrier telegraph channels (all of type "B")

between the various capitals were still few in number, being from Perth to Adelaide, 5; Adelaide to Melbourne, 10; Melbourne to Sydney, 10; and Sydney to Brisbane, 4 only. Each of these telegraph systems required for its operation a "carrier line" over the long interstate routes, and this fact, from the point of view of the Lines Design Engineer, soon came to be regarded as a disadvantage since, with the growing demands for telephone channels between the capitals, the physical telephone lines in use for the type "B" telegraph systems could not be used for multi-channel carrier telephone systems, nor could they be used for physical broadcast relay channels between the capitals.

In 1935 the first voice-frequency carrier telegraph system was placed in service between Sydney and Tamworth. It provided 18 duplex channels which were operated over one channel only of a 3-channel telephone carrier system. The proposal to install this system had been initiated by the writer (then located in New South Wales) and justified because of the large savings in operating costs to be achieved by the abolition of Tamworth as a large telegraph repeating centre, and on the line plant side by the savings in maintenance costs from the abolition of old iron wire telegraph lines, including the disposal of an entire pole line 160 miles in length then existing and carrying physical iron wire telegraph lines between Maitland and Tamworth. All these advantages were actually secured, but in addition valuable floor space was recovered at Tamworth to meet other requirements, while the grade of telegraph service was very greatly improved since the stability and improved maintenance practices of "carrier" working were also secured for the benefit of the telegraph channels.

Experience with this first system led to the installation of other 18-channel V.F. systems

* Reprinted by permission from *The Telecommunication Journal of Australia*, June, 1944.

between Sydney and Wagga and Brisbane and Townsville to secure similar advantages on the operating side to those gained with the Tamworth system. A 12-channel V.F. system was also obtained for use between Sydney and Lismore, but at the outbreak of the European war in 1939 this was diverted and placed into service between Sydney and Canberra.

It will be seen that development between 1927 and 1939, regarded from the point of view of the number of systems installed and the number of telegraph channels provided, had been comparatively slow. The ability of the type "B" systems between the interstate capitals to handle heavy traffic loads had tended to restrict the introduction of additional systems, while the few V.F. systems in use had been installed between intrastate centres to secure operating advantages. In the main, the great bulk of the intrastate telegraph circuits were still provided by physical lines, many of them of inferior quality, being of iron wire (numbers of them more than 50 years old) or provided over circuits secured as by-products of telephone lines, viz., composite telegraph circuits or caihlos over physical telephone channels.

The outbreak of war with Japan in December, 1941, and the subsequent building up of armed forces in Australia from early in 1942 onwards, gave rise to heavy demands upon the Department to provide additional telegraph communication facilities throughout Australia. For the reasons outlined in the foregoing, the Department was very badly placed to produce at short notice numbers of additional communication channels. The telegraph channels required by the forces were those capable of operating teleprinter or teletype services over long distances between headquarters located in capital cities and the forward areas, many hundreds of miles, and in some cases over 2,000 miles distant. The problem was rendered more difficult by the fact that each branch of the defence forces required to have available at all times one or more services for its own individual use. Thus, instead of the traffic being brought to one centre and passed to other states or centres over a few channels using machine systems, as under Departmental practice, the demand quickly grew for numbers of separate channels each capable of operating

continuously teleprinter and teletype services over long distances.

The quickest and most economical way of providing groups of efficient telegraph channels capable of meeting the conditions required was by the use of multi-channel carrier telegraph systems. As the position stood in 1942, the means available of meeting the requirements of the defence forces were very limited, nor was the outlook in respect of securing additional equipment to provide additional facilities very bright. Prior to 1942, all carrier telegraph systems installed in the Commonwealth had been obtained from overseas. Only one firm in Australia, Standard Telephones & Cables Pty. Ltd., was proceeding with local manufacture, but production had not been finalised at that stage. Due to the war, overseas supplies had practically ceased. Indeed, with the single exception of one 18-channel system of B.G.E. manufacture, delivered from Great Britain late in 1941, no carrier telegraph equipment could be secured from any source outside Australia for $4\frac{1}{2}$ years from the outbreak of the European war, i.e., from 1939 to 1944.

The Department had never attempted the manufacture of equipment of this type in its own workshops, but had during 1941 endeavoured to develop a 4-channel carrier telegraph system, now known as the type "R" system, in order to take advantage of the frequency spectrum between 3,000 and 5,200 cycles which is available with some telephone carrier systems, between the highest frequency of the V.F. telephone channel and the lowest frequency of the first carrier channel. This system was intended for operation over physical lines without intermediate repeaters, and, therefore, had application to special cases only.

A test of the capabilities of local manufactures by the invitation of short-dated tenders early in 1942 for carrier telegraph equipment showed that it was hopeless to expect any supply from this source other than from Standard Telephones & Cables Pty. Ltd. within 12 months. Standard Telephones & Cables Pty. Ltd. already held an order for one 18-channel V.F. system, but their supplies of raw materials were very limited. Arrangements were made with the company to vary the order to provide for two 9-channel systems in lieu of one 18-channel system in order to spread the available materials, and thus

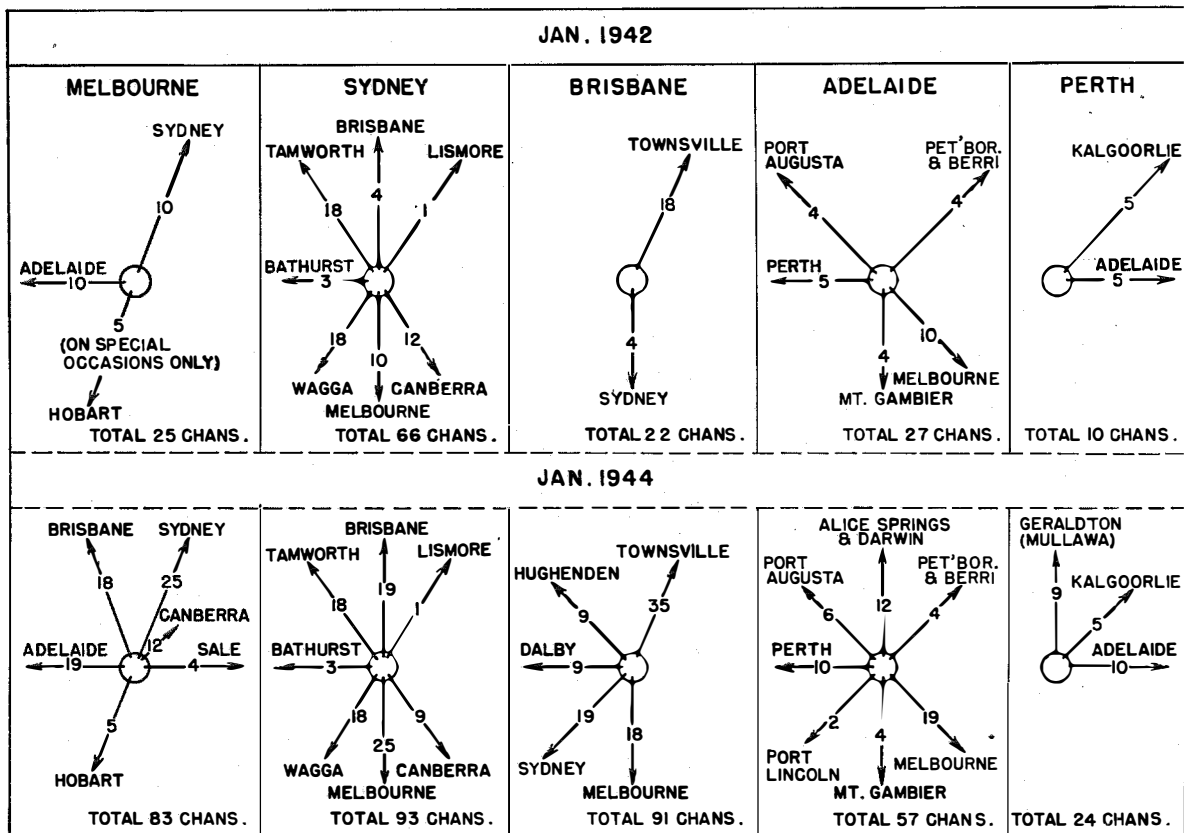

FIG. A

the benefits, and a little later a further two 9-channel systems were ordered. Steps were also taken to develop and improve the 4-channel type "R" system with a view to producing several of them departmentally to meet immediate needs. Two 4-channel systems of this type were completed early in 1942, and carrier telegraph service on these systems was provided from Adelaide to Alice Springs by February, 1942, and to the Darwin area by April, 1942, the systems being operated in both cases over carrier telephone channels.

By this time it was becoming obvious that demands from the services were increasing so rapidly that even the use of a number of 4-channel systems would provide temporary relief only. The difficulties in attempting manufacture of further systems or systems providing a greater number of channels was the lack of high permeability core material for the manufacture of filters or any supplies of the special sensi-

tive telegraph receiving relays used in these systems. Fortunately, a limited supply of core material, suitable for use with voice frequencies, had been located with a local firm in Melbourne. This core material was secured, and the difficulty of receiving relays was partly overcome by the development of a suitable relay, known departmentally as the P.R. 10. Manufacture of supplies of these relays, which has been described in a previous issue of *The Telecommunication Journal of Australia* (Vol. 4, No. 4, June, 1943), was commenced in the Melbourne workshops, and the design and development of voice-frequency carrier telegraph systems of nine channels as well as some of four channels was undertaken. To increase the rate of output, contracts were let for component parts and some complete panel units, and while the main manufacture and assembly was undertaken in the Melbourne workshops, manufacture of several systems was also undertaken by the Transmission Engineers,

Sydney and Adelaide, filters and relays being supplied from Melbourne. This spreading of effort proved very successful in securing quick results, as it enabled the production of several systems in a short time, and played no small part in alleviating the heavy demands for long distance telegraph services which persisted during the second half of 1942.

Manufacture of this type of equipment proceeded during 1942 and 1943 as rapidly as all the difficulties of labour shortage and shortage of special components and raw materials permitted. By the end of 1943, 15 systems providing four, six, or nine channels each, had been produced and installed. Standard Telephones & Cables Pty. Ltd., Sydney, completed four 9-channel systems in the same period, and subsequently supplied further equipment to permit the extension of two of these 9-channel systems to 12 channels and two of them to 18 channels. (Incidentally, 14/4-channel terminals—equivalent to 7/4-channel systems—were also produced in the Department's Melbourne workshops during the same period for use by the Australian Army Signals Corps on mobile communication units in forward areas or for use in combat areas outside Australia proper.)

The establishment of this "production line" and the subsequent installation of the equipment transformed the position of the Department in respect to meeting telegraph channel requirements throughout Australia not only for the armed forces but to cope with the very heavy

increase in telegraph traffic over the Department's own services, due to the widespread activities associated with the mobilisation of the national resources for the war effort and the extensive rearrangements of population brought about thereby.

The extent to which additional carrier telegraph facilities were provided in this period is indicated by the following figures:

	Channels	Mileage
Channels and mileage of channels provided by carrier telegraph systems existing in Australia at 31/12/41.....	240	114,240
Channels and mileage of channels provided by carrier telegraph systems existing in Australia at 31/12/42.....	384	234,040
Channels and mileage of channels provided by carrier telegraph systems existing in Australia at 31/12/43.....	590	358,840

It will thus be seen that during the single year, 1942, the carrier telegraph mileage which had been built up over the previous 15 years throughout the Commonwealth was doubled, and by the end of 1943 it had been trebled.

The new installations had spread throughout every mainland State of the Commonwealth. Since so much of this new equipment is in use for military purposes, the locations of the various systems installed cannot be given at this stage, but an indication of the manner in which each State has shared in the building up of channels over the period mentioned is shown by Fig. A, which compares the carrier telegraph channels routing through each of the five mainland

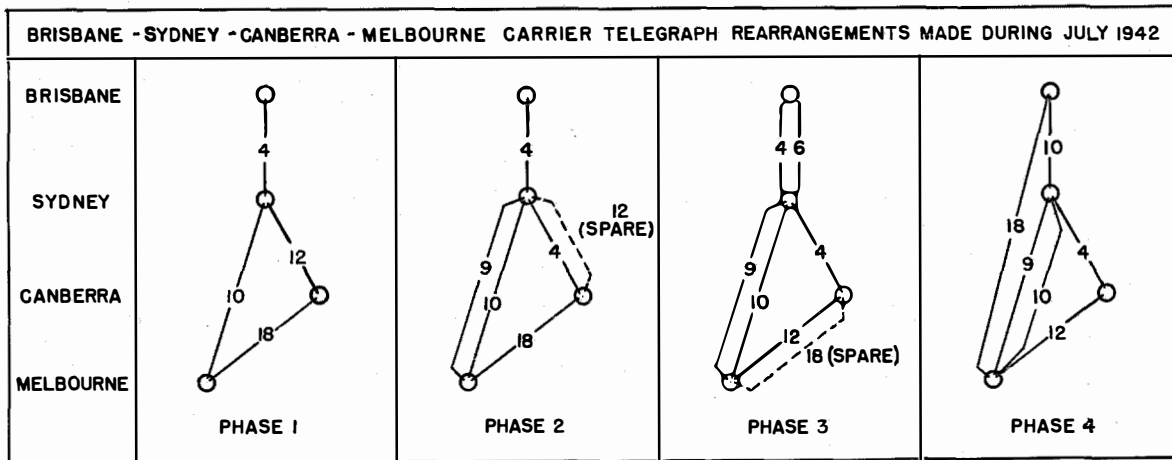

FIG. B

capital cities of the Commonwealth in January, 1944, with those existing two years previously in January, 1942.

In meeting various requests for numbers of additional telegraph channels at short notice over long distances with little or no spare equipment available it was necessary from time to time to adopt unusual expedients. A striking example is provided by the rearrangement and extension of carrier telegraph facilities between Brisbane, Sydney, Melbourne, and Canberra which took place during July, 1942. The importance of the results secured and the expedition with which they were carried through, despite the many difficulties to be overcome at that time, were such that a description of the various steps involved and the manner of carrying them into effect will be of general interest.

All channels provided by the carrier telegraph systems in use at June, 1942, between the capital cities concerned were fully occupied, there were no spares on any route, and the most serious bottle-neck was the link between Brisbane and Sydney, where four type "B" carrier channels only were available. (See Fig. B, Phase 1.) In anticipation that there would be need for some additional telegraph facilities between Brisbane and Sydney in the early future, the manufacture, departmentally, of equipment designed to extend this system to its full capacity of 10 channels had been commenced in Sydney a few months earlier, and completion of this additional equipment was expected early in July. The only carrier telegraph equipment on hand and not actually in use at this time was one 4-channel type "R" system, the manufacture of which had just been completed by the Department in Melbourne. Delivery was, however, expected early in July of a 9-channel system from Standard Telephones & Cables Pty. Ltd., Sydney. This latter system was intended for installation between Melbourne and Adelaide.

An examination of the routing of the various existing circuits provided by the inter-capital systems showed that although ten channels were provided on the direct route between Melbourne and Sydney, a further nine channels were derived by extending nine of the channels in the 18-channel system between Melbourne and Canberra through to Sydney over nine of the chan-

nels in the Canberra-Sydney 12-channel system. Thus of the existing circuits in the Melbourne-Canberra and Canberra-Sydney systems, there were, at that time, only nine direct channels serving between Melbourne and Canberra and three direct channels between Canberra and Sydney.

Standard Telephones & Cables Pty. Ltd. met the Department's request for early completion of the 9-channel system, and it was delivered in Sydney on July 3, but without the all-important receiving relays, which were not available until a week later. As the first step in a complete plan it was decided to install this system on the direct route between Sydney and Melbourne. Since heavy transport congestion existed at the time over the railway system due to the break of gauge at Albury, the terminal for use at Melbourne was brought from Sydney by road by Departmental gas-producer truck. This truck, on its return journey, took back to Canberra and Sydney respectively the two terminals of the departmentally manufactured type "R" system. The new 9-channel system on the direct Melbourne-Sydney route was brought into service on or about the 12th of July, after the receipt, by post, of the receiving relays. This installation permitted the diversion to the direct route of the nine Melbourne-Sydney channels previously routed via Canberra. This diversion left three channels only to be catered for between Canberra and Sydney. The type "R" system was then brought into operation between those centres and the three existing channels transferred to it, thus throwing free all channels in the existing 12-channel system between Canberra and Sydney and providing one extra circuit.

The Sydney terminal of this 12-channel system was then transported, again by departmental truck, from Sydney to Melbourne and set up to work into the terminal at Canberra over the Melbourne-Canberra route. The cut-over of this system permitted the transfer thereto of the nine direct Melbourne-Canberra circuits (leaving three spares), and permitted the complete recovery of the 18-channel system between Melbourne and Canberra. In the meantime, the additional equipment to extend the Sydney-Brisbane type "B" system by six channels had been completed in Sydney and the equipment for the Brisbane end transferred there. This equipment varied

in many respects from the existing type "B" equipment, but, subject to some initial difficulties in arranging interconnection with the existing equipment, was brought into operation on the 15th of July.

The final step to be undertaken was the placing into operation between Melbourne and Brisbane of the 18-channel system which had been freed between Melbourne and Canberra. This involved the transfer to Brisbane of the 18-channel terminal from Canberra. In the carrying out of the rearrangement to this stage, numerous minor difficulties had been met and overcome, but the time within which it had been intimated that the series of operations to provide all the channels required could be completed, viz., the end of July, was now running short, only eight days remained. It was decided, therefore, to attempt the transfer by air, and with the assistance of the U. S. Army Signals Corps, arrangements were made to transport by bomber plane the Canberra terminal with all its accessories, weighing, in all, some 18cwt., from Canberra to Brisbane. This was successfully accomplished, the plane picking up the terminal at Canberra and landing it without mishap the same day in Brisbane. Installation of the Brisbane terminal had been prepared for and was pushed forward with expedition. Suitable telephone channels had already been selected, over which the telegraph service was to operate direct between Brisbane and Melbourne without any intermediate telegraph equipment in Sydney. The successful cutting-over into service of this system on July 31 completed the operations.

The various stages of this operation will be followed by reference to phases 1 to 4 of Fig. B.

These changes enabled all the circuits which had been requested by the military authorities between the four capitals to be provided with a margin of two spares between Melbourne and Brisbane and a similar number between Melbourne and Canberra. For the introduction of a small quantity only of new equipment, the mileage of carrier telegraph channels was increased by over 100 percent from 18,700 to 40,600. The whole operation described was completed in five weeks from the time that advice of requirements was first received by the Department and without the loss or closing down at any stage

of any of the existing telegraph channels, which comprised some of the most important circuits in the Commonwealth. The time occupied between the actual receipt of the complete equipment for the 9-channel system used between Melbourne and Sydney, which permitted the series of operations to commence, until the final cut-over into service of the 18-channel system between Melbourne and Brisbane was 21 days only.

Apart from development in numbers of channels and channel mileage, a large number of technical improvements have been made in the period between the installation of the first carrier telegraph system in 1927 and the present day, particularly in relation to the generation of frequencies, the elimination of sending relays, the introduction of level compensating circuits, and numerous other specific electrical and physical aspects. An important development, however, is that experience has resulted in a clearer conception of the problems associated with carrier telegraph transmission, and considerable advancement has been made towards determining the possibilities and limitations of systems with respect to distortion and interference. This aspect will be discussed in more detail in the technical articles describing the various systems.

It is interesting to review the part played by carrier telegraphs in the evolution of telegraph practice over long distances. As the range of telegraph communication extended, the necessity to utilise expensive lines to the best advantage led to the development of two main systems of telegraphy—high speed systems and multiplex systems. High speed systems obtain increased output, speeding transmission beyond the ability of a single operator by using automatic transmitters which can be fed with perforated tape prepared in advance by a number of operators; multiplex systems, on the other hand, assign the line in turn to a number of operators, thus obtaining high channel carrying capacity by transmitting a number of messages simultaneously, each operator working at normal speed.

With the advent of carrier telegraph systems capable of subdividing a line or, alternatively, a speech channel into a large number of telegraph channels, at the same time offering greater flexibility and obviating the need to retain

complicated mechanical apparatus, it became economical to assign one channel end per operator on the basis of machine operation using teleprinter or teletype machines. In this connection it should be mentioned here that the earlier carrier telegraph system, the type "B," had sufficient channel band width to take a quadruple multiplex machine system and the narrower band widths suitable for teleprinter-teletype-transmission were first introduced with the voice-frequency systems.

The success of the voice-frequency carrier telegraph system is due, firstly, to its adaptability to economical operation over telephone circuits by making use of the whole frequency band usually allocated for speech purposes, and secondly to the fact that it requires transmission characteristics similar to those of the telephone speech channels. Since it is now regular practice to operate voice-frequency telegraph systems over carrier telephone channels, it may be said that every advance directed towards an improvement in quality and performance of telephone circuits, such as improved band width, better equalisation, and regulation of circuits, reduction of interference and crosstalk, all contribute towards improved telegraph transmission. With voice-frequency telegraph systems, wherever satisfactory telephone circuits are established, high speed reliable telegraph channels can be provided. Under the conditions operating in the Commonwealth, where both services are operated by the one administration, the telegraph and telephone services thus tend to become not so much competitors as services complementary to one another.

In order to describe the details of the various systems in use a series of articles has been prepared by Mr. J. L. Skerrett. These will also cover the technical developments which have taken place in carrier telegraph working and survey some of the problems associated with the establishment of a reliable long distance telegraph network. The first paper (Part I) is reprinted in this issue of *Electrical Communication*. The second article will have reference more particularly to the Australian Post-office type "R" and Voice-Frequency systems, while the third will discuss the telegraph transmission aspects of carrier telegraph systems and the associated telegraph apparatus.

PART I—J. L. SKERRETT

The Type B Carrier Telegraph System

The earliest development in carrier telegraph working commenced with the introduction of the type "B" system. This system provides up to a maximum of 10 duplex (duo-directional simplex) channels on an open-wire pair, and several such systems have been installed in the Commonwealth principally between capital cities. Experience over a number of years has proved them to be of simple yet robust design and, despite the absence of refinements included in later carrier telegraph systems, the type "B" systems in use are rendering excellent service, although they require more maintenance and lack the flexibility of later systems.

In the type "B" system 20 separate carrier frequencies are employed, 10 in each direction of transmission, the low frequency group (3.33–5.50 kc./sec.) being transmitted in the B-A direction and the high frequency group (6.50–10.00 kc./sec.) in the A-B direction. The separation between adjacent carrier frequencies ranges from 240 cycles per second at the lower end of the frequency band and in the A-B direction progressively widens until it is 500 cycles per second wide between the two highest frequencies.

A block schematic of a type "B" channel is shown in Fig. 1.

Carrier telegraph, as well as carrier telephone, systems employ alternating currents of different frequencies to provide for the transmission of several messages simultaneously over the same pair of wires without interfering with each other or with the normal telephone and telegraph circuits on these wires. In the telegraph systems the alternating current or carrier current of a channel is interrupted to form the signalling characters just as a direct current is interrupted in a simple telegraph circuit. The various messages can be separated from each other at the receiving end because, in the type "B" system, each frequency is capable of being selected from all of the others by means of an electrical selecting circuit commonly known as a "tuned circuit." To permit interconnection in the plant, relays or their equivalent (*viz.*, static modulators) are employed at the transmitting end, connected by means of direct current circuits to the sending

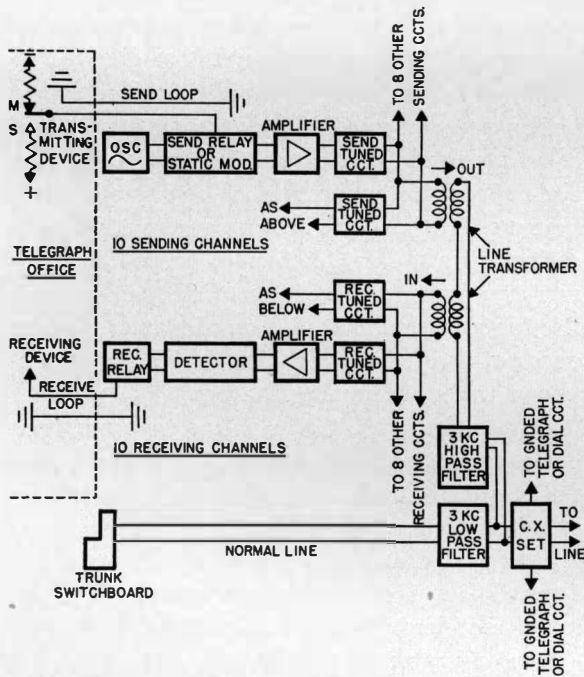

Fig. 1—Type B carrier telegraph system (10 duo-directional simplex channels).

operators' keys, machines, or transmitters. At the receiving end the carrier currents after rectification are caused to operate polarised telegraph relays which subsequently control the receiving sounders or printers.

As the frequencies used in the type "B" system are above the commercial voice-frequency range it will be seen from Fig. 1 that, with the aid of normal high and low pass line filters having a 3,000 cycles cut-off, the type "B" system can be superimposed on a telephone circuit without interfering with the normal use of the line for voice frequency telephone and composite telegraph working.

The channel equipment at the sending end consists of an oscillator generating the required frequency, a send relay or static modulator, a single stage amplifier, and a sending tuned circuit. For receiving incoming signals a receiving tuned circuit, a two-stage amplifier, a detector, and a receive telegraph relay are provided. In setting up the channels the sending oscillator and tuned circuit are set to the correct frequency, and at the far end the corresponding receiving circuit is tuned accurately to that frequency from the received carrier current itself.

CIRCUIT OPERATION (see Fig. 1). The carrier current, which is an alternating current generated by the oscillator, is connected to the amplifier and until interrupted to form the telegraph signals is continuously transmitted to line via the sending tuned circuit and line transformer. The oscillator output is intermittently blocked by the operation of the sending relay or static modulator which is controlled by direct current telegraph signals from the send telegraph loop.

Incoming pulses of carrier frequency, after being selected by the proper receiving tuned circuit, are amplified and detected, and the pulses of rectified current in the anode circuit of the detector valve operate the carrier receive relay, which, from its tongue, delivers double current signals to the local telegraph receive loop.

If it is desired to extend the range of a type "B" system, repeaters are inserted at intervals of approximately 150 miles. These repeaters are similar to the conventional carrier telephone repeater, and a block schematic diagram, which is self-explanatory, is shown in Fig. 2.

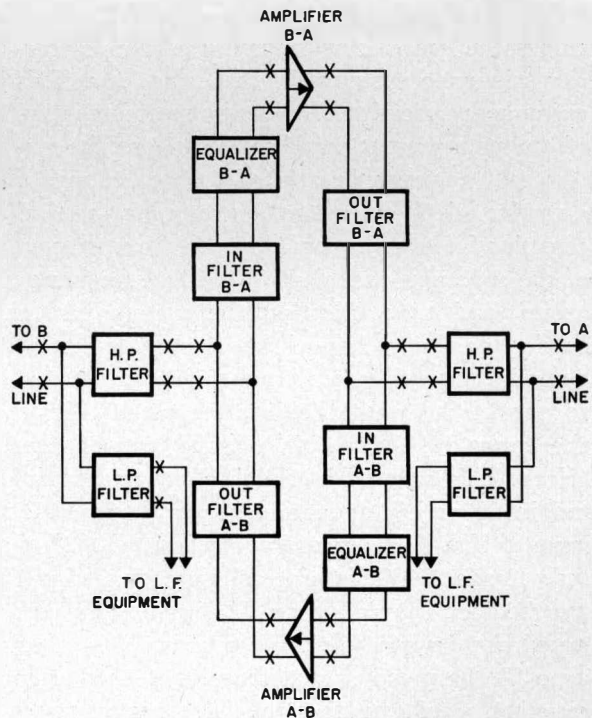

Fig. 2—Type B carrier telegraph repeater.

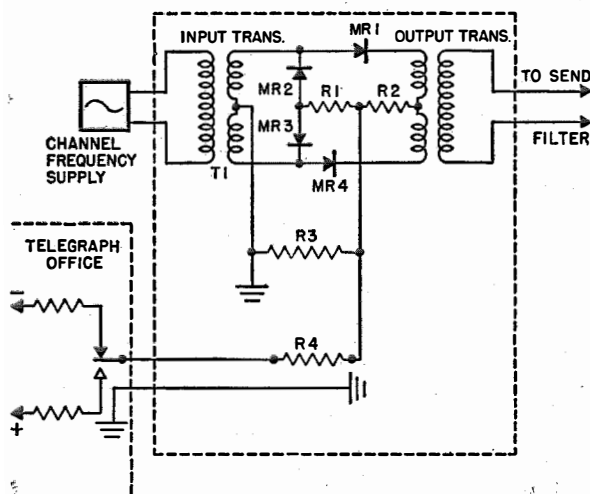

Fig. 3.

It will be noted that separation between the grouped frequency bands in each direction of transmission is obtained at repeaters by means of directional filters.

As the type "B" system completely absorbs the frequency spectrum between 3.3 and 10.0 kc./sec., its application to an open wire line precludes the use of single and three-channel carrier telephone systems on the same pair. This extravagant use of the frequency spectrum is one of the main present-day disadvantages. The system can, however, be applied to one channel of a carrier telephone system by retuning the A-B direction frequency group down to the same part of the spectrum occupied by the B-A frequency group, and then injecting the system into a carrier telephone channel whose modulator and demodulator oscillators have also been retuned to permit the wanted sidebands to fall within the range of the requisite band pass filters. (Note: This method is explained in greater detail in an article appearing in the June, 1942, issue of *The Telecommunication Journal of Australia*, page 27.) This process is greatly assisted by the fact that all type "B" oscillators and tuned circuits can be readily tuned to any other type "B" frequency. An alternative method after retuning would be to apply the system to a four-wire physical circuit in the range 3.3-5.5 kc./sec., thus setting free the frequency spectrum

above 6 kc./sec. for the application of 3-channel carrier telephone systems.

The above methods are only justified as expedients to employ existing equipment to the best advantage and thus clear valuable high-frequency circuits for the application of carrier telephone systems. They offer no advantage over the application of a 9- or 18-channel voice-frequency carrier telegraph system over the same transmission medium, and, in fact, the latter method does not involve any retuning of the carrier telephone system channel oscillators.

The earliest type "B" systems were mounted on floor pattern units and require considerable floor space. Later systems were mounted on standard carrier type racks.

STATIC MODULATORS VERSUS SENDING RELAYS. The use of a non-linear conductor (e.g., metal rectifiers) as a variable impedance under the control of the polarity of the applied voltage has been extensively employed in recent years for many telecommunication circuit purposes, and one of the main applications has resulted in the replacement of sending relays by the now familiar static modulators. The static modulator was first introduced with V.F. carrier telegraph systems, and its advantages over the sending relay were so marked that steps were taken during 1938 to replace all 215A type sending relays in type "B" systems with static modulator circuits.

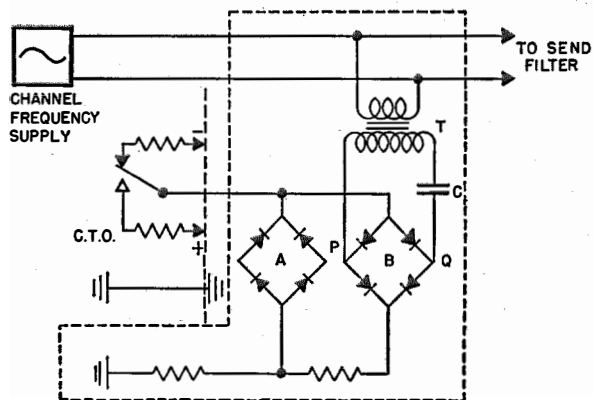

Fig. 4.—Static modulator circuit.

Figs. 3 and 4 illustrate two types of static modulator circuit used in carrier telegraph working. Referring to Fig. 3, the static modulator unit consists of an input transformer T1, modulator unit comprising copper-oxide rectifier units MR1-4, resistors R1, 2, and output transformer T2. Resistor R4 is the current limiting resistor in the send telegraph loop, and its value is chosen to limit the current in the loop to the standard value of 25 milliamps. The shunt resistor R3 ensures that the current applied to the rectifier network is limited to the correct value.

When the transmitting telegraph apparatus at the telegraph office is in the "marking" condition negative potential is applied to the static modulator and rectifiers MR1 and MR4 become conducting. At the same time rectifiers MR2 and MR3 become non-conducting, and thus offer a high impedance shunt across the secondary winding of T1. Thus, carrier frequency from the oscillator is permitted to pass freely to the send filter unit, the attenuation in the static modulator being that due to the transformers alone.

When the potential applied to the static modulator is reversed due to the application of a "spacing" signal, the rectifier impedances are reversed (i.e., MR2 and MR3 become conducting and MR1 and MR4 non-conducting), resulting in a low resistance shunt across the secondary of transformer T1, together with a high resistance series path to the passage of carrier frequency from the channel oscillator.

Referring now to Fig. 4, the two bridges A and B, which are identical, are made up of copper oxide metal rectifier elements. Transformer T has a 10 to 1 ratio step up and the primary is connected across the output of the channel frequency source whilst bridge B is connected across the secondary. The impedance of bridge B between the points P, Q, is therefore effectively in shunt across the carrier frequency source, and modulation is effected by varying the value of this reflected impedance from a low value during "spacing" signals to a high value during "marking" signals, the variation being controlled by the magnitude and direction of current in the send telegraph loop. When a "marking" signal is applied bridge A presents a low forward resistance and the send loop current flowing through it and the series resistance R biases

the rectifier elements in bridge B in the backward direction so that they present a high impedance and carrier frequency is transmitted to line. When the polarity of the applied d.c. is reversed on a "spacing" signal bridge A becomes high resistance and bridge B low resistance so that the shunting loss is high and practically no carrier passes to line.

Typical values of the a.c. impedance across points P and Q are 300,000 ohms and 100 ohms during "marking" and "spacing" elements respectively, the corresponding reflected impedances through transformer T being 3,000 ohms and 1 ohm.

Bridge A and its series resistance serve to produce the correct value of negative bias across bridge B in the "marking" condition and tend to equalise the d.c. loop current in the marking and spacing intervals. The condenser C prevents the flow of d.c. through the secondary winding of transformer T.

A static modulator may, therefore, be said to modulate the carrier frequency of the channel with which it is associated in accordance with the polarity of the telegraph signals applied from the telegraph office resulting in pulses of carrier to line corresponding to a "marking" signal and cessation of carrier during a "spacing" signal.

Looked at in another light the static modulator may be regarded as an attenuator switching device such that with an applied d.c. polarity of negative potential the attenuation offered to the a.c. channel frequency is of the order of 4 db., whereas upon reversal of the d.c. polarity to a positive potential the attenuation increases to 40 decibel. In other words the "discrimination" of the static modulator is, on the above quoted values, 36 decibel. Thus, whilst in the blocking condition carrier is still passed to line, the level is so low that it is below the threshold of operation of the receiving equipment. In early static modulators "discrimination" values of the order of 30 decibel were obtained, but in circuits employed in the last two or three years the "discrimination" has been increased to values of 40 and 50 decibel due mainly to steeper voltage-resistance characteristics of the rectifier elements employed.

The elimination of apparatus which contains moving parts and requires regular maintenance

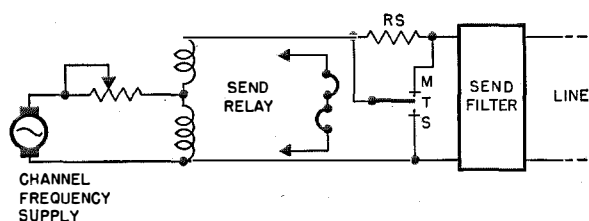

Fig. 5—Send-relay circuit.

attention to ensure operation free from contact and bias troubles is attractive, and the discrimination of the latest static modulator circuits is such as to definitely establish their superiority over mechanical send relays.

It is interesting to note that, whilst various static modulator circuits have been tried in American practice, their use has not been extended because they imposed certain operating limitations on the associated telegraph apparatus in use. Such limitations have not been experienced with the telegraph apparatus and arrangements in use in Australian practice.

In order to eliminate the difficulties caused by high resistance contacts of sending relays, one American company evolved the interesting circuit arrangement shown in Fig. 5. The auto transformer is connected so as to provide a high impedance looking towards the generator, while R_s , which is the order of 50,000 ohms, provides a corresponding high resistance towards the output, the sending filter being suitably padded to ensure a satisfactory termination. With this arrangement the contact resistances in both the "marking" and "spacing" positions may vary considerably without seriously affecting the transmitting efficiency.

Voice-Frequency Carrier Telegraph Systems

The major developments in long-distance telegraph transmission have taken place since the introduction of multi-channel voice-frequency telegraph (M.C.V.F.) working.

The frequencies used are the odd multiples of a base frequency of 60 cycles per second in the range 420–2,460 cycles per second. Reasons for the adoption of this frequency grouping are as follow:

(1) The average telephone channel has an approximate linear frequency response between 300

and 2,600 cycles per second, and this consideration sets the lower and upper limit to the choice of telegraph carrier frequencies for M.C.V.F. systems which must be capable of operating over a normal telephone circuit.

(Carrier telephone channels complying with the revised C.C.I.F. specification for increased band width 300–3,400 cycles per second are now being introduced in the plant in Type J open wire 12-channel systems and in cable carrier systems. It will be appreciated that M.C.V.F. systems operated over channels of this band width can be extended to an upper limit of 3,180 cycles per second, thus permitting the derivation of 24 to 26 telegraph channels from one telephone circuit.)

(2) The required telegraph transmission speed decides the band width required for each channel. Although normally used for machine teleprinter working (50 bauds), M.C.V.F. systems are designed to cater for a transmission speed of 66 bauds. This provides a margin over the required speed of 50 bauds, and permits the connection of two or three channels in tandem.

In M.C.V.F. systems the channel carrier frequency is modulated with a low frequency (up to 25 cycles per second) for teleprinter transmission. It is usual to transmit the carrier and both sidebands, as it would be exceedingly difficult in the small band width available to design

TABLE I.

Channel Number		Channel Frequency c.p.s.	Channel Number		Channel Frequency c.p.s.
18-Channel System (120 c.p.s.)	9-Channel System (240 c.p.s.)		18-Channel System (120 c.p.s.)	9-Channel System (240 c.p.s.)	
1		420	10	5	1500
2	1	540	11		1620
3		660	12	6	1740
4	2	780	13		1860
5		900	14	7	1980
6	3	1020	15		2100
7		1140	16	8	2220
8	4	1260	17		2340
9		1380	18	9	2460

channel band pass filters with sufficiently sharp cut-off to eliminate the carrier and one side band. Moreover in telegraph transmission, wave front distortion is of primary importance, and correct phase relationship between carrier and sideband is essential. With the carrier in the centre of the transmission band the phase compensation is automatic. If the carrier were suppressed, it would involve reintroduction at correct frequency and phase at the distant terminal with consequent synchronisation and phase correction adjustments.

As the channel carrier frequency and both sidebands are transmitted an effective band width of 33 cycles per second each side of the carrier frequency is required. In practice the channel width must be approximately twice this value to give a margin for filter design and allow the filter pass band to be approximately linear over the required frequency band.

(3) The actual frequencies adopted were chosen with a view to preventing interchannel interference which may occur due to non-linearity of loading coils, amplifiers, etc. With regard to interference frequencies, those of greatest magnitude are the second harmonics and simple sum and difference products of any pair of carrier frequencies.

By choosing a basic frequency and using the odd multiples the sum and difference products will always be even multiples, and these then lie midway between the carrier frequencies, that is, at a point where the stop band characteristic of the channel band pass filters has maximum attenuation.

Two main types of M.C.V.F. system are employed in the network, viz., the 18-channel M.C.V.F. system (120-cycle spacing) and the 9-channel M.C.V.F. system (240-cycle spacing). Each channel can be operated on a duo-directional simplex basis. The channel frequency allocations are as shown in Table I.

Frequency Allocation—18- and 9-Channel V.F. Systems

Both systems can, of course, be initially installed, partially equipped and later extended to their full capacity. The 9-channel 240-cycle spaced system is of advantage between centres where development beyond a maximum of nine channels is not anticipated.

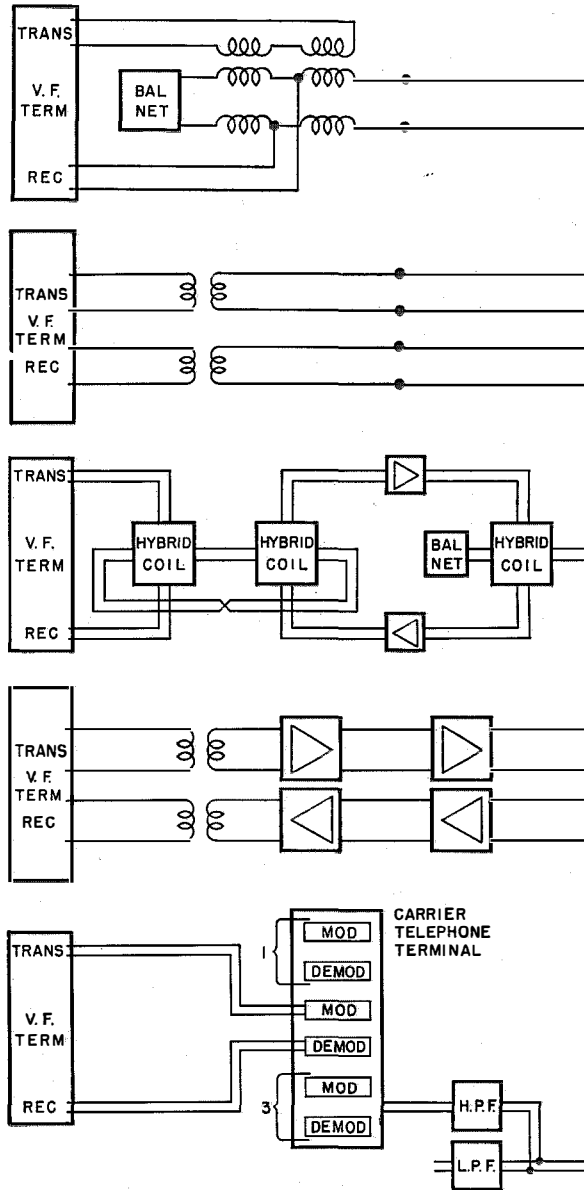

Fig. 6—Circuit applications—M.C.V.F. systems.

(1) Two-wire voice-frequency physical circuits operating over aerial or cable wires, providing a maximum of nine duo-directional simplex telegraph channels as shown in Fig. 6a.

(2) Four-wire voice-frequency physical circuits, operating over aerial or cable wires, providing a maximum of 18 duo-directional simplex telegraph channels as shown in Fig. 6b.

(3) Two-wire voice-frequency physical circuits operating over aerial or cable wires and equipped with intermediate or terminal amplifiers, providing a maximum of nine duo-directional simplex telegraph channels as shown in Fig. 6c.

(4) Four-wire voice-frequency physical circuits operating over aerial or cable wires, and equipped with intermediate or terminal amplifiers, providing a maximum of 18 duo-directional simplex telegraph channels as shown in Fig. 6d.

(5) The transmit and receive paths of a carrier telephone channel, providing a maximum of 18 duo-directional simplex telegraph channels as shown in Fig. 6e.

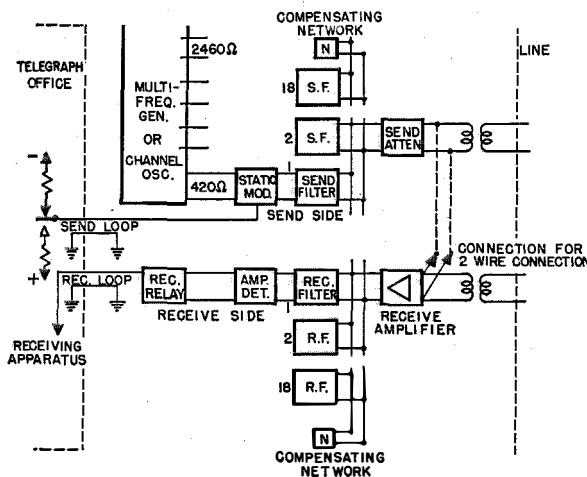

Fig. 7—M.C.V.F. systems—block schematic.

CIRCUIT APPLICATION. Whilst the frequency range of M.C.V.F. systems permits their application to normal two-wire or four-wire voice-frequency circuits derived from open wires or cable pairs, they are generally operated over and absorb a carrier telephone channel. This is largely due to the fact that carrier telephone circuits exist between the centres where telegraph facilities are required, and, in addition, are more stable and have a lower overall equivalent than the corresponding physical circuit. It is likely that future extension of four-wire voice-frequency circuits in cables will be followed by the derivation of M.C.V.F. circuits therefrom. In this connection it is of interest to note that the M.C.V.F. systems in use can, in general, be operated over a circuit having a maximum transmission equivalent of 24 decibel at 3,000 cycles per second. (This is equivalent to a distance of 400 miles on a 200 lb. copper circuit not equipped with amplifiers.)

Except in special circumstances M.C.V.F. systems are operated over four-wire circuits because they employ the same frequencies for each direction of transmission. If they are applied to a two-wire circuit the number of derived channels is halved, thus, in an 18-channel system nine different frequencies have to be employed in each direction. Moreover, it is usual to delete the mid-channel for hybrid or directional filter discrimination purposes so that only eight duo-directional simplex channels are obtained.

The various circuit applications are shown in Fig. 6.

Fig. 7 shows in block schematic form the equipment provided for one channel of a M.C.V.F. system. Signals from the telegraph office consisting of positive and negative impulses are applied to the static relay which is also supplied with the appropriate channel frequency furnished from the channel oscillator.

In the static modulator the polarity of the applied telegraph signals controls the flow of channel frequency in such a way as to produce impulses of the frequency in a code corresponding to the transmitted telegraph intelligence. Thus, when a marking signal is applied to the static modulator the carrier current generated by the channel oscillator is passed to the send filter where the unwanted products generated in the static modulator are rejected. Each channel frequency is then applied to line via the two-wire/four-wire line equipment panel.

At the receiving end the incoming a.c. signals applied to the two-wire/four-wire line equipment panel are passed to the receive amplifier where the level is restored to a suitable value and then applied to the channel receive filters. Each receive filter selects its allotted channel frequency and in each channel the signals are then applied to an amplifier detector where they are converted to d.c. impulses which operate the carrier receive relay, whose line winding forms part of the plate circuit of the detector valve.

The contacts of the receiving relay are connected to the positive and negative telegraph battery supplies, and the tongue of the relay supplies positive and negative signals to the receive telegraph loop, corresponding to the signals originated at the transmitting end.

A typical 18-channel system is shown in Fig. 8.

The 18-channel systems are accommodated on standard 10 ft. 6 in. high carrier racks. A first installation for a main centre complete with duplicate machine generators usually requires five racks, and occupies a total floor space of approximately 8 ft. 6 in. \times 1 ft. 3½ in. The bays consist of channel bays equipped for either six or nine channels depending on the type of system, battery supply, and generator bay capable of accommodating circuits for 10 complete systems and a fuse bay accommodating circuits for five

complete systems. In some cases an additional bay accommodating distortion measuring equipment is provided.

The equipment is mounted single sided with respect to the panels and double sided with respect to the racks. The wiring is completely accessible and complete circuits are contained on each side of the rack. The racks and panels are finished in the now familiar aluminium finish.

The jack and bay panels are hinged in order to retain double sided mounting arrangements and make most economical use of space. In lieu of meters in each separate send and receive loop, as in the type "B" system, a separate meter panel is provided with facilities for patching into any channel.

Protection is provided by the use of resistance lamps in plate and telegraph loop circuits and fuses in filament circuits.

Each initial installation is complete with a relay test table for adjustment of the carrier receive relays which are of the 209FA polarised telegraph relay type or their equivalent. The test table provides for measurement of neutrality, transit time, and sensitivity of the relays which must be routined at frequent intervals in order to give satisfactory performance.

It is anticipated that future development will result in the replacement of the mechanical receive relay by a combination of valves termed a valve relay. Whilst suitable valve relays for particular purposes have been developed and give complete satisfaction for those purposes, a satisfactory generally applicable alternative to the electromagnetic relay is not yet available.

EFFECTS OF TELEPHONE CIRCUIT LEVEL VARIATIONS ON THE OPERATION OF M.C.V.F. SYSTEMS. In carrier telegraph transmission, where carrier is transmitted to line during a marking element and suppressed during a spacing element, we have the equivalent of single current transmission, and the receive relay requires a bias (either mechanical or electrical) in order to restore its tongue to the spacing contact on cessation of a marking signal. As the restoring force is fixed when the channel is "lined up" for operation by reversals transmitted from the distant terminal any subsequent variations in received signal level will result in bias distortion.

In M.C.V.F. working the necessity for maintaining constant amplitude of the received signal

is dependent on the shape of the signal envelope. If the signal envelope were "square topped" in form, as shown in Fig. 9a, the bias distortion introduced by small changes in amplitude would be zero, whereas when the signal envelope is of sinusoidal shape small changes in amplitude are sufficient to cause considerable distortion. The signal applied to the channel band pass filters takes a definite time to build up to a steady state value. The extent of the building-up time is largely a function of the filter characteristics and increases with reduction in filter band width. This building up time causes the applied signal to be tapered at both ends as shown in Fig. 9b. The effect of line level variations on the rectified current is shown in this latter diagram, where the dotted line represents the steady bias condition and indicates the point where the incoming signal strength is sufficient to operate the carrier

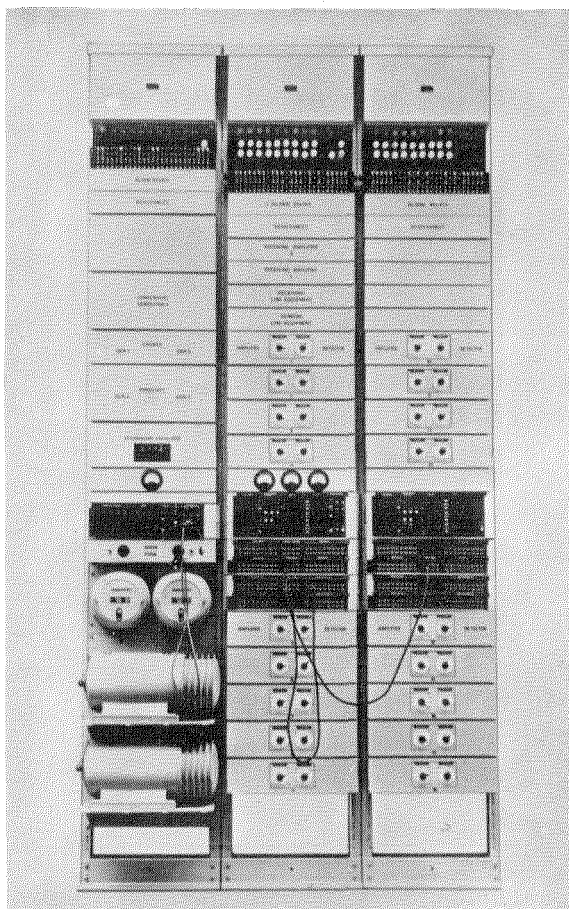

Fig. 8—Typical 18-channel V.F. carrier terminal.

receive relay from space to mark. With respect to the normal line-up signal the effective mark signal (x) commences earlier and finishes later, whereas signal (y) commences later and finishes earlier, with a resultant distortion in either case equal to $2t$. (It will be appreciated that in Fig. 9b we are dealing with one particular fixed band width having a constant building-up time represented by C, D, and therefore any change in the amplitude of the applied signal will produce a change in slope of the signal envelope as indicated.)

It is evident from a consideration of Fig. 9b that some form of regulation is necessary in order that signals of constant amplitude are applied to the carrier receive relay. This can be achieved either by ensuring that the telephone bearer circuit is held regulated to very close limits or by incorporating a level control feature in the carrier telegraph equipment. The former method is the most desirable in that all the equipment on any one circuit is thereby catered for, and a telephone channel on which the level variations are held to within ± 0.5 db. is satisfactory as a bearer channel for carrier telegraph systems. At present, however, the percentage of closely regulated telephone circuits in service is very small, and, whilst the proportion will steadily increase, this method cannot be completely adopted for some considerable time. It is, therefore, necessary to apply the level control feature to the M.C.V.F. system. This control is incorporated in the individual channel equipment because it cannot be satisfactorily applied

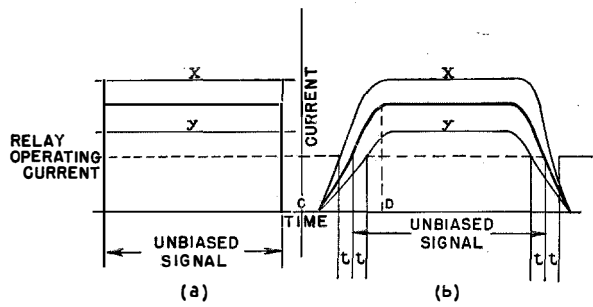

Fig. 9.

to any common amplifier equipment in the carrier telegraph system (unless a pilot control frequency was utilized), due to the fact that the input to such equipment is continuously varying in a fortuitous manner, dependent on the number of channels which may be marking or spacing at any one instant. All M.C.V.F. systems in use, therefore, include an automatic level control circuit in the channel amplifier detector units. The inclusion of a limiter circuit in the amplifier detector results in a slight increase in distortion as compared with an amplifier detector unit without limiting features. The increase in distortion, however, is negligible, particularly when the large improvement in distortion during input level variations of the order of ± 5 db. is taken into account. Table II, indicating average distortion measurements of various types of telegraph signals with and without a limiter circuit in the amplifier detector unit, best illustrates this point.

TABLE II.

Detector Plate Current (mA)	10.2	10.25	10.5	4.5	6	7.9	10.25	12	13.5	14.8	16
Signal Input Level	-5 db.	Ref. -20 db.	+5 db.	-3 db.	-2 db.	-1 db.	Ref. -25 db.	+1 db.	+2 db.	+3 db.	+4 db.
Test Signal				Complete Failure							
1:1 % Distn.	3	3	4		20	10	3	7	14	21	24
2:2 %	1	1	2		19	7	1	9	15	22	25
5:1 %	4	4	4		21	8	2	9	15	20	25
1:5 %	4	3	3		21	9	2	9	15	20	25
Paris %	4	3	4		22	9	3	9	14	20	25
Paris Rev. %	4	3	4		22	9	3	9	14	20	25
	Limiting Circuit Connected			Limiting Circuit Disconnected							

This may also be taken as a comparison of distortion on type "B" and M.C.V.F. systems, as the former system does not include any automatic level control, and as a result close attention by the maintenance attendant is necessary to secure uninterrupted service.

The most common method of compensation for the effects of slow changes in amplitude of the applied signal depends for its operation on the change of grid-cathode impedance of a valve when the potential on the grid reaches a point where grid current commences to flow, and also on the rectifying property of the grid cathode circuit. The elements of a limiter of this type are shown in Fig. 10, the value of grid bias depending on whether the valve is being used as an amplifier or rectifier.

Considering a signal of large amplitude applied between grid and cathode, the carrier receive relay will operate just after the commencement of the building up period of the signal envelope, and when the peak amplitude exceeds the normal grid bias, grid current flows and charges condenser C. As a result, a voltage is developed across the C, R, combination, with resultant additional negative bias applied to the grid. As the time constant of the C, R, combination is large in comparison with the time between successive half waves, and is actually chosen to be greater than the longest interval between marking elements in the telegraph 5-unit code, the new bias value will be maintained on the grid, providing the amplitude of the input signal remains constant. Any variation in amplitude of the input signal will cause a variation of grid current with a resultant change of bias on the grid. By a suitable choice of circuit constants, the plate current is held substantially independent of input level variations over a range of ± 7.5 decibel. The additional bias developed across the limiting circuit may be applied to other stages to give greater control, and is usually applied to the amplifier stage preceding the detector in amplifier detector units. A typical amplifier detector circuit will be described in detail in the next article in this series.

FILTERS. The functions of the send filter associated with each channel of a M.C.V.F. system are, firstly, restriction of the frequency band width transmitted to line for each channel. This restriction of band width is necessary because

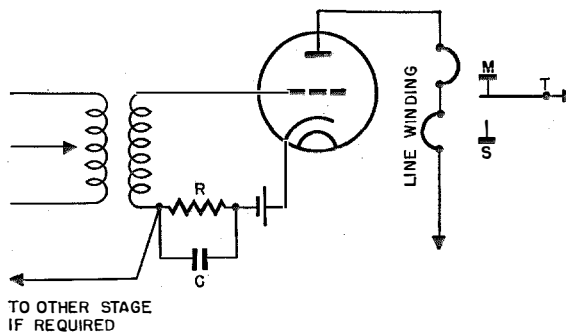

Fig. 10—Simple grid limiter.

the modulation of the carrier frequency of each channel with the applied d.c. telegraph signals in the static modulator results in the generation of a wide spectrum of side band frequencies on either side of the carrier. Suppression of the unwanted harmonics reduces the power to line and decreases the possibility of interchannel interference. The restricted band width also prevents harmonics of the channel carrier frequencies from passing to line and perhaps causing interchannel interference in a similar manner. The send filters also serve to present a high reactive impedance to the carrier frequencies of other channels at the commoning point of the filters, thus ensuring that the carrier output of any one channel is not dissipated in, or modulated by, the sending equipment of other channels which are connected in parallel with it.

The function of the receive filters is to divide the multi-frequency signals received over the line into the separate channel frequency bands, and direct these to the appropriate amplifier detectors.

In the eighteen channel M.C.V.F. systems, the send and receive filters are band-pass filters, having a band width of 120 cycles per second symmetrical about the mid-band frequency. In order to fulfil the functions outlined above, a single section suffices for each send filter and two sections for each receive filter.

The filter design is of particular interest in that internal impedance transformations are necessary in order to permit the use of components which are commercially realisable at reasonable cost. The transmission requirements which have to be satisfied are as follows:

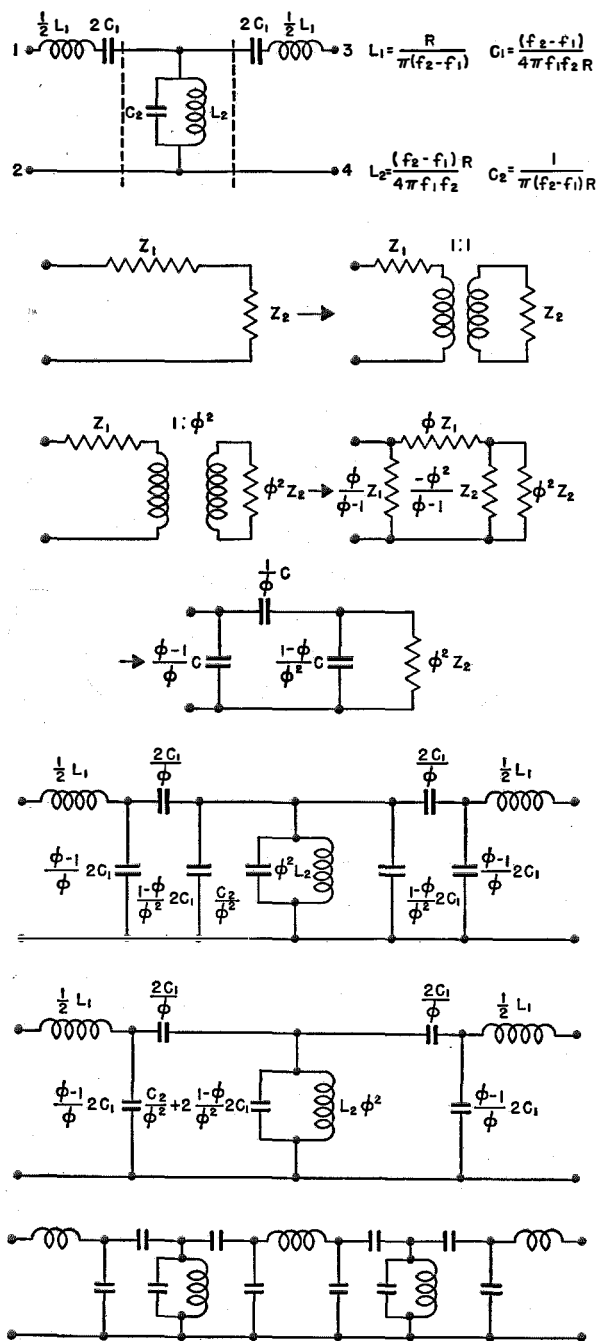

Fig. 11—Filter design.

- (a) Prototype band pass filter section.
- (b) Equivalence used in designing impedance transformation filter sections.
- (c) Band pass filter section with internal impedance transformations. Electrically equivalent to (a).
- (d) Send filter (schematic).
- (e) Receive filter (schematic).

(a) "The attenuation characteristic shall be approximately symmetrical about the mid-band frequency."

(b) "The phase characteristic shall be approximately linear and of equal and opposite symmetry about the mid-band frequency."

(c) "It is desirable that the attenuation of each receive filter ± 35 cycles per second from its mid-band frequency should not be more than 2.5 decibel above the attenuation at the mid-band frequency."

(d) "The attenuation of each receive filter ± 120 cycles per second from its mid-band frequency (that is, at the mid-band frequencies of the directly adjacent filters) should not be less than 30 decibel above the attenuation at the mid-band frequency."

The confluent band pass filter section of the constant K type was employed as the basis of design since it satisfies the above requirements and they can be produced at less cost than M derived sections.

Fig. 11a is a representation of a full section with mid-series termination, together with the formulae for calculating the impedance elements. In these formulae f_1 and f_2 are the lower and upper cut-off frequencies respectively, and R the impedances between which the filter is to be inserted, R for the filters concerned being a pure resistance of 600 ohms. The band width (f_2-f_1) is 120 cycles per second.

From an examination of the formulae it will be found that condenser C_2 is of constant magnitude if the band width (f_2-f_1) and the impedance R are constants and for the factors given is $4.421 \mu\text{F}$. Also, since the band width is small compared with the product of the cut-off frequencies, the value of the inductance L_2 is of small value, and decreases with increase in frequency. From a manufacturing and a cost viewpoint, the values of both C_2 and L_2 are very unsatisfactory, and, in order to avoid the difficulties involved in employing these values, use has been made of impedance transformed filter sections by introducing the equivalent of an ideal step-up transformer in front of the shunt elements, and the equivalent of an ideal step-down transformer immediately after these elements.

The derivation of the equivalence employed in designing such filter sections is shown in Fig.

11b. The resultant filter section is shown in Fig. 11c, but, as the condensers $\frac{1-\phi}{\phi^2}2C_1$ are in parallel with the shunt element condenser of value $\frac{C_2}{\phi^2}$, they can be replaced by a condenser of value $\frac{C_2}{\phi^2} + 2\frac{1-\phi}{\phi^2}2C_1$. The final band pass filter section with internal impedance transformations and electrically equivalent to the prototype band pass filter section is shown in Fig. 11d. This is a single section send filter. A two-section receive filter is shown in Fig. 11e.

It will be noted that the impedance transformations increased the number of elements required per filter, but the advantages gained more than offset such an increase. By a suitable choice of ϕ the shunt condenser across the inductance is reduced in value such that it is manufactured as a mica dielectric type of similar dimensions to the series condensers. Also, the shunt inductance approaches a value of the order of the series inductances and does not then require a difficult manufacturing technique. All filters are of the unbalanced type, and the general attenuation characteristics of a group of 18 send and receive filters are shown in Fig. 12. The filters are mounted in compact form on standard 19 in. x $3\frac{1}{2}$ in. panels.

COMPENSATING NETWORK. The outputs of the send filters and the receive filters in an 18-channel system are connected in parallel, and at the common point compensating networks are connected across each parallel group of filters. These networks provide a flanking impedance and serve to improve the characteristics of the higher frequency filters. Compensating networks are not usually equipped on 6-, 9-, or 12-channel systems.

CARRIER SUPPLY. The individual channel frequencies for M.C.V.F. systems installed at important centres where the ultimate development is likely to exceed 36 channels are supplied from special machine generators. The output per channel is capable of feeding up to a maximum of ten 18-channel systems.

The machine generator consists of a motor and an inductor type alternator fixed to a common shaft. The 18 stator coils of the alternator are located in an outer shell, whilst unwound

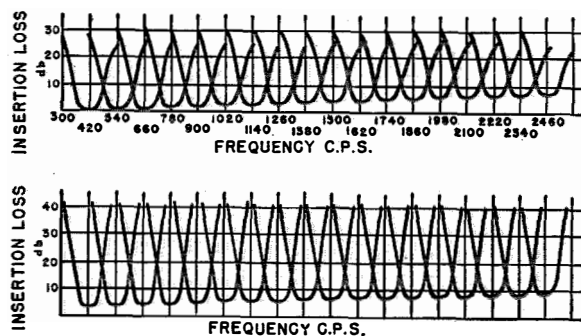

Fig. 12—Attenuation characteristics. Send and receive filters, 18-channel V.F. system.

rotors keyed to the shaft rotate and produce in the stator coils the respective channel frequencies.

In order to maintain the speed of the generator substantially constant over the normal range of variation of input voltage, and with a varying load (from 1 to 10 systems), a centrifugal governor assembly is fixed to a shaft extension on the motor. The governor includes a flat spring which, under the action of centrifugal force makes contact with an adjustable contact screw. Current is applied to the contacts through carbon brushes, and a commutator assembly which reverses the direction of current flow through the contacts, thus minimising the transfer of metal from one contact to the other. When the contacts close they short-circuit portion of the motor field resistance. This resistance is variable, and is set to a value which, when alternately opened and short-circuited, controls the mean value of field current, thus compensating for supply and load variations.

The generator speed is checked stroboscopically by applying the output of a very stable 1,020 cycles per second oscillator (tuning fork control) to either of two neon lamps, which illuminate a stroboscopic disc mounted on the shaft. The stroboscopic disc is divided into 34 black and 34 white sectors, and as the correct speed of the generator is 3,600 r.p.m., a total of 2,040 black and white sectors pass a given point in one second. The speed is checked by viewing the stroboscopic disc by the light of the neon lamp, which flashes 2,040 times per second. If the speed is correct, the disc appears to be stationary. The speed tolerance is ± 0.1 percent, so that if speed is incorrect adjustment should ensure

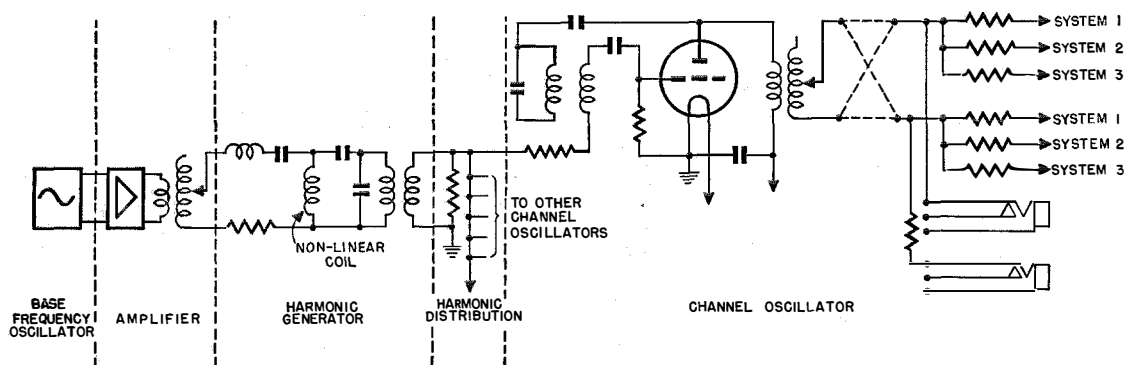

Fig. 13—Harmonic oscillator.

that not more than two white or black sectors pass a given point in one second. Duplicate machine generators are provided at each installation. The motor operates from the 24-volt filament battery and the drain when running is approximately 5 amperes.

OSCILLATORS. In small installations comprising one or two systems individual channel oscillators are employed, as the more expensive machine generator installation is not warranted. These oscillators are generally of the resistance stabilised type where the circuit elements are chosen to obtain frequency stability and low harmonic content of the output wave form, and special care in choice of components, particularly the tuned circuit elements, is necessary in order to ensure this required frequency stability with normal temperature and battery supply variations. It is desirable that the carrier frequency of any oscillator be held to within ± 6 cycles per second, with ambient temperature variations between 50 and 115 deg. F., and heater and anode voltage variations up to 10 percent of the nominal values. The channel oscillators include a control to adjust the frequency, and in systems employing oscillators the usual routine is to line up the oscillator through the send and receive band pass filters for maximum detected current, thus ensuring that the oscillator frequency is set to the mid point, or point of lowest attenuation, of the filters.

As the oscillator output is interrupted by a static modulator or send relay contacts, it is necessary to arrange that the output be insensitive to the large impedance changes which occur in the change from marking to spacing. This is

usually achieved by designing the oscillator for large output, this being then reduced to the required value (of the order of 1 milliwatt) by an attenuator which masks these impedance variations.

An interesting application of carrier supply equipment capable of feeding a large number of systems from channel oscillators controlled by a master oscillator has been employed in the latest American type carrier telegraph systems, some of which are now being installed in the network. This method is an application of the carrier supply arrangements employed in open wire and cable type 12-channel carrier telephone systems. As many as 50 channels of different M.C.V.F. systems may be operated from one oscillator, and this method therefore compares favourably with machine generator supply systems.

Fig. 13 indicates in schematic form the harmonic control arrangements, consisting of a base frequency oscillator, amplifier, harmonic generator, and the connections to the channel frequency oscillators.

When the carrier supply is obtained from valve oscillators operating independently, it is found that at frequent intervals the carrier frequencies have a phase relationship which produces a high peak value of line current. In a machine generator supply system the phase of each carrier frequency is fixed by the design of the machine in a random relationship to all the other frequencies, and the peak current values are normally much lower than with an equivalent system employing individual channel oscillators.

The frequent recurrence of high peak currents

in the line tends to overload any amplifier equipment in circuit with a corresponding increase in interchannel interference.

The harmonic control system ensures that all channel oscillators are held in an exact harmonic relationship. The output of the high stability base frequency oscillator is amplified and passed through a special iron core non-linear coil, thus generating a very peaked wave containing all the odd harmonics of the base frequency, which is introduced into the grid circuits of all the channel frequency oscillators. The channel oscillator tuned circuits act as filters to select the particular harmonic to which they are tuned, and each channel oscillator falls in step with the respective harmonic of the base frequency.

The oscillator frequencies are thus held in a synchronous relation by the harmonic control, but, unlike the machine generator case cited above, the phase relationships are no longer random. The phase position of each channel frequency oscillator output depends on its frequency adjustment and varies a little, dependent upon whether the oscillator, when operating independently of the base frequency control, is adjusted to a slightly higher or lower frequency than that of the base frequency harmonic. Investigations have shown that when each oscillator has been adjusted as an independent unit to be close to its correct frequency, and the harmonic control circuit is then applied, the phase of each carrier is, on the average, fairly close to the position where each current reaches a positive maximum at the same instant. This, therefore, is unsatisfactory from the standpoint of high peak values. However, with the carrier current outputs of the various channel oscillators fixed in phase, it becomes possible to reduce the peaks at the sending end by reversing the output leads

of a certain number of oscillators. Experiments have shown that a particular combination of reversed channels is superior to any other of the many possible combinations for average applications, and this method has been found in practice to be very satisfactory in keeping peak line current values within reasonable limits.

In large offices containing more than five 18-channel M.C.V.F. systems it is usual to provide two complete banks of channel oscillators and duplicate base frequency oscillators with change-over facilities for use in cases of failure. It is interesting to note that failure of the base frequency oscillator or harmonic control equipment does not cause a service interruption, because the channel frequency oscillators continue to function independently at their tuned frequency. Under this condition the tendency to interchannel interference increases, but the immediate effect on working channels would in general be negligible.

From the foregoing remarks it will be seen that future development in carrier telegraph working will mainly consist of the application of 18-channel M.C.V.F. systems, with a probable derivation of 24 channels on wide band telephone channels, on main trunk routes. The 9-channel M.C.V.F. systems (240-cycle spacing) will be employed between important centres where a maximum of 9 channels would be adequate for traffic purposes. There are other systems of recent development employing other previously unused portions of the frequency spectrum which are particularly applicable to centres where 9 or more channels are not required, and also where the provision of a bearer telephone channel is not justified. A description of these systems forms part of the next article, which will deal more particularly with systems of Departmental manufacture.

Recent Telecommunication Developments

INTERNATIONAL TELECOMMUNICATION LABORATORIES, INC.—This corporation was created March 27, 1945, to co-ordinate the research efforts of I. T. & T. affiliated laboratories,* as well as engineering activities of numerous manufacturing companies and communication operating systems throughout the world. E. M. Deloraine, Director of the Federal Telephone and Radio Laboratories, Inc., is President of the new organization.

Recently outlined in this journal was description of work on Pulse Time Modulation, a field in which I. T. & T. Laboratories have pioneered. Another contribution of historic importance is the Micro-ray System operating on a wavelength of about 18-centimeters with very sharply concentrated beams, first demonstrated across the Strait of Dover in 1931, and installed commercially between Lympne, England, and St. Inglevert, France, in 1933. Prominent among medium and short wave broadcasters of the highest power was the 120-kilowatt Prague transmitter (1932); one of the most recent BBC Empire transmitters rated at 100 to 130 kilowatts; Radio Rome (two 100-kilowatt transmitters completed in 1939); and the Paris 30-kilowatt Eiffel Tower television transmitter.

When Paris recently was retaken in the swift Allied advance, Les Laboratoires LMT, like practically all industrial plants in that city, were found intact and are now producing communication equipment for the U. S. A. Armed Forces and their allies. These Laboratories had a radio station working for the U. S. Army within 24 hours after the City's liberation and many additional stations shortly thereafter.

Since their formation in 1941, the New York Laboratories of Federal Telephone and Radio Corporation have concentrated on development projects for the Armed Forces of the United Nations. Important contributions to the war effort include the development of marine direction finders designed to meet specific requirements of the United States Navy; direction

* In New York, Federal Telephone and Radio Laboratories, Inc.; in London, Standard Telephones and Cables Ltd.; in Paris, Les Laboratoires, Le Matériel Téléphonique.

finders providing radio bearings for military aeroplanes; and the radio instrument landing system for aircraft now adopted by the U. S. Army Air Force and the Civil Aeronautics Administration as standard. They also have contributed aerial navigation systems providing aid in the operation and guidance of aeroplanes in flight, and have provided the 200-kilowatt vacuum tubes for the Office of War Information's new global shortwave transmitters.

Following September, 1939, the Laboratories of Standard Telephones and Cables, Ltd., London, vastly expanded their activities. No intimation of the amazing developments of the subsequent war years can now be given.

Today, I. T. & T.'s Laboratories are wholly engaged in aiding the war effort. The advent of the International Telecommunication Laboratories, Inc., is a harbinger of significant contributions in the postwar period to the rapidly advancing electrical communication art.



SECOND STAR TO ARMY AND NAVY E AWARD TO FTR LABORATORIES—In a letter announcing the award on December 2, 1944, Under Secretary of War Robert P. Patterson stated, "In maintaining the fine record which first brought you distinction, you have set an inspiring example for your fellow Americans on the production front."

Established in New York early in 1941, the Federal Telephone and Radio Laboratories have grown from an organization of seven persons to a present total of approximately 900. The value of their scientific and development contributions was recognized through the Army and Navy E award granted on April 20, 1943, approximately two years after their formation.



FTTR 200-KW HIGH FREQUENCY TUBE—Federal Telephone and Radio Laboratories have developed the tube shown in the accompanying illustration for international broadcasting and

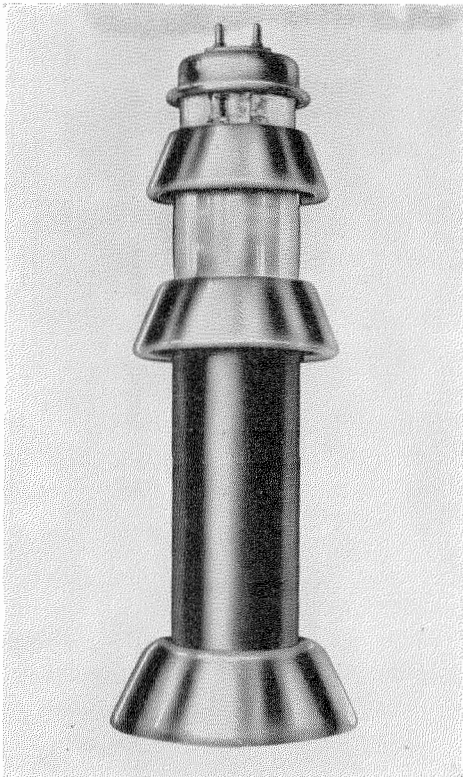

FTR 200-kilowatt high-frequency tube.

FM applications as well as for high frequency heating. The following are its principal characteristics:

Power output is 200 kilowatts when operated as an oscillator in class C telegraphy, with a maximum plate voltage of 18 kilovolts and a maximum plate dissipation of 150 kilowatts. In operation as a class C, plate-modulated amplifier, the power output is set at 100 kilowatts with maximum plate voltage of 12.5 kilovolts and maximum plate dissipation of 75 kilowatts. The filament consumes 625 amperes at 25 volts and has an available thermionic emission of 120 amperes.

• • •

TWO-HUNDRED-KILOWATT TRANSMITTERS FOR OFFICE OF WAR INFORMATION—Two high-power, high-frequency broadcasting transmitters, more powerful than any existing transmitters in the U. S. A., are being constructed for the Office of War Information by the Federal

Telephone and Radio Corporation. Operating at two locations on the West Coast of the United States, these units will augment radio coverage of the entire Pacific area, from Siberia to Australia and from Hawaii to India. Their power will guarantee reception of American broadcasts in territories occupied by the Japanese, as well as by far-flung stations of the United Nations forces.

Each station will be composed of three separate transmitters: one of 200 kilowatts and two of 50 kilowatts each. The equipment manufactured by Federal consists of the main units for a 200-kilowatt, high-frequency broadcast transmitter, a rectifier power supply, a 150-kilowatt modulator, a water cooling system, radio control panels and other auxiliary components. It will be used with existing 50-kilowatt, radio frequency channels to provide single-program, dual-frequency broadcasting at 50-kilowatt output and single-program, single-frequency broadcasting at 200-kilowatt output.

The power equipment, modulators, control panels and water cooling systems have been installed and are now in service as the main components of 50-kilowatt transmitters. Power amplifiers for 200-kilowatt output are being assembled in the Federal plant at Clifton, New Jersey.

• • •

FTR NEW INDUSTRIAL POWER TUBE—A compact power tube, first in a series especially designed for industrial use in high-frequency heating equipment, has been developed by the Federal Telephone and Radio Corporation. It embodies features that make it ideally suited for use in electronic heating equipment that must withstand the shocks and vibration incident to manufacturing operations.

Designed for water cooling (type F5302) or forced-air cooling (F5303), the new tube is supplied with 6" flexible copper leads permanently secured to the tube terminals. This feature obviates glass damage frequently encountered by industrial users in attaching and adjusting terminal clamps on the tube itself, and permits installation and maintenance by comparatively inexperienced personnel.

Other design features of this tube are its

unusually sturdy, conservatively spaced filament and grid elements, and an absence of ceramic insulation, both internal and external. An over-size filament insures abundant emission throughout the life of the tube, and an extra-heavy anode wall provides large thermal capacity for added protection against momentary overloads.

Conservatively rated under Class C power amplifier and oscillator conditions at 4,375 watts input, the tube operates at full rating at frequencies up to 50 megacycles. Maximum ratings are: DC Plate Voltage, 3,500 volts; DC Plate Current, 1.25 amperes; and Plate Dissipation, 2,500 watts. Filament current is 27.5 amperes at 11 volts. The overall height of the tube is approximately 7 inches with a maximum diameter of 3½ inches.

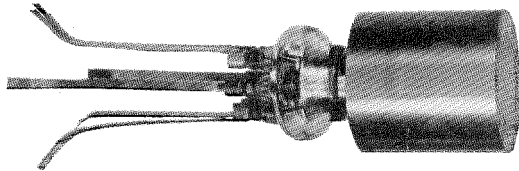

New FTR industrial power tube.

• • •

MACKAY RADIO CIRCUITS OPENED IN 1944—Mackay Radio and Telegraph Company established a press communication circuit between the U. S. A. and liberated France when Radio "25" was landed on a beachhead and placed in operation during the invasion of Normandy by the United Nations. The first equipment on this circuit employed a 1-kilowatt, high-frequency radio transmitter mounted on an Army truck. This transmitter followed General Patton's army inland and maintained continuous radio telegraph communication with the U. S. A. for press telegrams. On September 12, 1944, service was established from Paris through use of a transmitter made available by the French Administration. Then, in Paris, on October 16th, Mackay also established its 15-kilowatt, high-frequency radio telephone and telegraph transmitter which was shipped from the U. S. A. with a crew of 20 men.

Radio "25" now consists of these two transmitters. The 15-kilowatt Paris transmitter provides commercial radio broadcast and telegraph

service directly to the U. S. A., while a 1-kilowatt transmitter supplied by Le Matériel Téléphonique continues with the Third Army, the original transmitter having been "honorably discharged" after 14 or more rigorous moves across France.

Other circuits (telegraph) opened by Mackay Radio in 1944 were:

- New York–Montevideo (May 22, 1944)
- New York–Bombay (August 15, 1944)
- Algiers–Moscow (November 25, 1944)
- New York–Madrid (December 27, 1944)

The Algiers–Moscow circuit provides a relay link from New York to Moscow when conditions are unfavorable for direct communication between these two cities.

• • •

ADDITIONAL I. T. & T. SYSTEM RADIO CIRCUITS OPENED IN 1944—In Brazil, national radio telephone facilities were installed in the following cities for communication with Rio de Janeiro: Bahia, Belem, Curitiba, Fortaleza, Natal, Porto Alegre, and Recife. Stations at Manaus and Victoria are scheduled for completion in 1945. In Chile, a national radio telephone circuit was installed between Santiago and Coyhaique (December 28, 1944).

International radio telephone service was inaugurated to the U. S. A. from Porto Alegre (March 4, 1944) and from Belem (November 8, 1944).

Other international radio telephone circuits placed in operation in South America during 1944 were:

- Rio de Janeiro–Santiago (January, 1944)
- Rio de Janeiro–Madrid (April, 1944)*
- Santiago–La Paz (June 5, 1944)

During 1944, the following international radio telegraph circuits were also opened in South America:

- Rio de Janeiro–La Paz (January, 1944)
- Rio de Janeiro–Buenos Aires (May, 1944)
- Buenos Aires–La Paz (May, 1944)
- Rio de Janeiro–Santiago (May, 1944)
- Rio de Janeiro–Bogotá (November, 1944)
- Rio de Janeiro–Lima (November, 1944)
- Santiago–Buenos Aires (December 9, 1944)
- Santiago–La Paz (December 9, 1944).

* Reopening of circuit first established in 1930.

FTR NOMOGRAPHS—The Federal Telephone and Radio Corporation presented to participants in the Institute of Radio Engineers' 1945 Winter Technical Meeting, New York City, a folder containing 25 Nomographs. These Nomographs are the first of a series prepared to aid radio engineers in simplifying and facilitating calculations for U.H.F. and television applications. By their use it is possible to keep all variables constant except one and vary that one to obtain any specific result—a normally quite difficult procedure when families of curves are involved.

Some of the Nomographs now available are:

1. Band-Pass Circuit Design.
2. Characteristic Impedances of Various Transmission Line Configurations.
3. Deflection Sensitivity of Cathode Ray Tube
4. Cut-Off Frequencies for Circular Wave Guides.

Equations and limitations are given wherever the result might be questionable.

Although the quantity is limited, copies of these Nomograph folders may still be obtained by writing to the Editor, Electrical Communication, 67 Broad Street, New York 4, New York.

• • •

THE INSTITUTE OF RADIO ENGINEERS BEGINS A BUILDING-FUND CAMPAIGN—The Institute of Radio Engineers, at its Winter Technical Meeting in New York, January 24-27, inaugurated a campaign for the raising of \$500,000 for a Building Fund, in anticipation of postwar expansion of its service to the electronic and com-

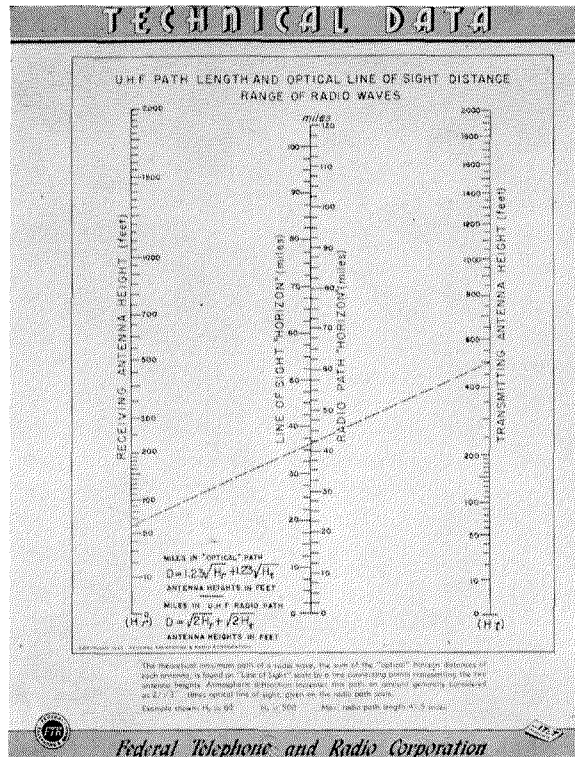

Specimen FTR nomograph.

munication industries. The Directors of the Society announced that they are leaving their plans flexible enough to permit their establishing new quarters jointly with other engineering and scientific societies if to do so ultimately proves desirable. The appeal for funds will extend to the Institute's membership and interested corporations.

Editor's Note: Electrical Communication ordinarily refrains from including items of this character in its pages. An exception was made in this case because of the importance of the I.R.E. in its contribution to the advance of the radio art—past, present, and future.

INTERNATIONAL TELEPHONE AND TELEGRAPH CORPORATION

*Affiliated Manufacturing, Telephone Operating,
and Cable and Radio Companies*

Manufacturing and Sales Companies

Licensed under patents of the International Standard Electric Corporation, New York, N. Y.

UNITED STATES OF AMERICA

FEDERAL TELEPHONE AND RADIO CORPORATION, Newark,
N. J.

INTERNATIONAL STANDARD ELECTRIC CORPORATION, Ex-
port Department, New York, N. Y.

BRITISH EMPIRE

STANDARD TELEPHONES AND CABLES, LIMITED, London,
England

Branches: Birmingham, Leeds, England; Glasgow, Scot-
land; Cairo, Egypt; Calcutta, India; Johannesburg,
South Africa.

CREED AND COMPANY, LIMITED, Croydon, England

KOLSTER-BRANDS LIMITED, Sidcup, England
STANDARD TELEPHONES AND CABLES PTY. LIMITED, Syd-
ney, Australia

Branches: Melbourne, Australia; Wellington, New Zea-
land.

BELGIUM

BELL TELEPHONE MANUFACTURING COMPANY, Antwerp

FRANCE

COMPAGNIE GÉNÉRALE DE CONSTRUCTIONS TÉLÉPHO-
NIQUES, Paris

LE MATÉRIEL TÉLÉPHONIQUE, Paris

LES TÉLÉIMPRIMEURS, Paris

LIGNES TÉLÉGRAPHIQUES ET TÉLÉPHONIQUES, Paris

PORTUGAL

STANDARD ELECTRICA, Lisbon

SPAIN

STANDARD ELÉCTRICA S.A., Madrid

SWEDEN

ARTIBOLAGET STANDARD RADIOFABRIK, Stockholm

SWITZERLAND

STANDARD TELEPHONE ET RADIO S.A., Zurich

Branch: Berne

ARGENTINA

COMPAÑÍA STANDARD ELECTRIC ARGENTINA, Sociedad
Anónima, Industrial y Comercial, Buenos Aires

BRAZIL

STANDARD ELECTRICA, S.A., Rio de Janeiro

CHILE

COMPAÑÍA STANDARD ELECTRIC, S.A.C., Santiago

Telephone and Radiotelephone Operating Companies

ARGENTINA

UNITED RIVER PLATE TELEPHONE COMPANY, LIMITED,
Buenos Aires

COMPAÑÍA INTERNACIONAL DE RADIO (Argentina), Buenos
Aires*

BOLIVIA

COMPAÑÍA INTERNACIONAL DE RADIO BOLIVIANA, La Paz*

BRAZIL

COMPANHIA TELEFONICA PARANAENSE, S.A., Curitiba

COMPANHIA TELEFONICA RIO GRANDENSE, Porto Alegre

COMPANHIA RADIO INTERNACIONAL DO BRASIL, Rio de
Janeiro*

CHILE

COMPAÑÍA DE TELÉFONOS DE CHILE, Santiago

COMPAÑÍA INTERNACIONAL DE RADIO, S.A., Santiago*

* Provides radiotelephone and radiotelegraph services.

† Provides radiotelephone and radio broadcasting services.

CUBA

CUBAN TELEPHONE COMPANY, Havana

MEXICO

MEXICAN TELEPHONE AND TELEGRAPH COMPANY, Mexico
City

PERU

COMPAÑÍA PERUANA DE TELÉFONOS LIMITADA, Lima

PUERTO RICO

PORTO RICO TELEPHONE COMPANY, San Juan

RADIO CORPORATION OF PORTO RICO, San Juan†

Cable and Radiotelegraph Operating Companies*

ALL AMERICA CABLES AND RADIO, INC., New York, N. Y.

COMMERCIAL CABLE COMPANY, THE, New York, N. Y.

MACKAY RADIO AND TELEGRAPH COMPANY, New York,
N. Y.

* Controlled by American Cable & Radio Corporation.

CUBAN ALL AMERICA CABLES, INC., THE, New York, N. Y.

SOCIEDAD ANÓNIMA RADIO ARGENTINA, Buenos Aires,
Argentina

Marine Radio Companies

MACKAY RADIO AND TELEGRAPH COMPANY, Marine Divi-
sion, New York, N. Y.

INTERNATIONAL MARINE RADIO COMPANY LIMITED,
Liverpool, England

COMPAÑÍA RADIO AÉREA MARÍTIMA ESPAÑOLA, Madrid, Spain